

Eventide®

the next step®

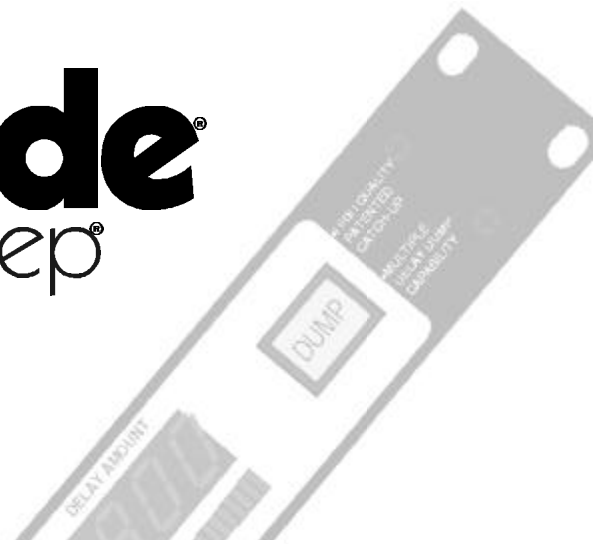

MODEL BD500 BROADCAST DELAY ----- OPERATOR'S MANUAL

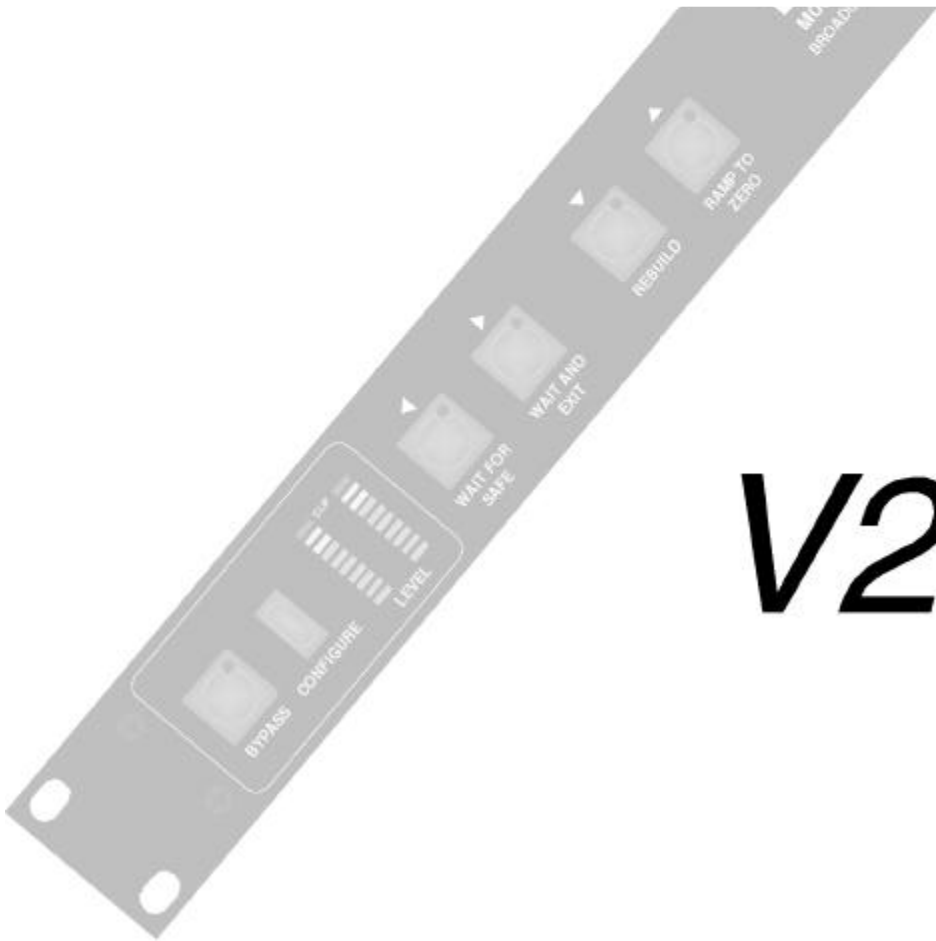

V2.5

Contents

Chapter 1 Introducing the BD500	1
Front Panel	2
Rear Panel	3
Audio Connections	4
Chapter 2 Operation	5
Installation	5
<i>Rack Mount</i>	5
<i>Connect AC and Turn On Power Switch</i>	5
<i>Level Meters</i>	5
<i>Connect Audio Inputs</i>	6
<i>Connect Audio Outputs</i>	6
Understanding BD500 Profanity Delay Functions	7
<i>REBUILD - Increase the delay gradually</i>	7
<i>RAMP TO ZERO - Decrease the delay gradually</i>	7
<i>WAIT FOR SAFE - Bring delay from 0 seconds to 4 seconds quickly</i>	7
<i>WAIT AND EXIT - Decrease the delay to 0 seconds quickly</i>	7
<i>SNEEZE - Edit the delay before a bad noise happens</i>	7
<i>DUMP - Edit the delay after a bad noise happens</i>	7
Operation as a Profanity Delay	8
Modes	8
Functions and Features	8
<i>Starting a Show Segment with REBUILD</i>	8
<i>Starting a Show Segment with WAIT FOR SAFE</i>	9
<i>Ending a Show Segment with RAMP TO ZERO</i>	9
<i>Ending a Show Segment with WAIT AND EXIT</i>	9
<i>DUMP Button</i>	10
<i>SNEEZE Button</i>	10
<i>Delay Amount Display</i>	10
Operation as a Precision Fixed Delay	11
Controlling the Fixed Delay	11
<i>Usage Notes</i>	11
Chapter 3 Configuration	13
<i>Password Protection</i>	13
<i>Restoring Factory Defaults</i>	13
Table of Configuration Variables	14
Configurable Variables	16
Appendix A Optional AES/EBU Digital Audio	19
Connection	19
Configuration	19
Operation	19
Notes and Warnings for AES/EBU Operation	20
Remote Connector	21
Appendix B Basic Remote Control	21
Appendix C Optional Remote Control/Signalling	23
Remote Connector	23
Configuring Optional Rear Panel Inputs and Outputs	24
<i>Input Commands not available via front panel</i>	24
Appendix D Optional Auxiliary Connector for Control Signal Delay	27
Appendix E Optional RS-232 Control	29
Appendix F Diagnostics	33
Start-up Sequence	33
Startup Switches	34
Error Processing	34
Error Codes	35
Appendix G Specifications	45
Appendix H Warranty Information	47
Index	49

Chapter 1 Introducing the BD500

The Eventide BD500 is designed to enable a broadcast licensee to prevent obscene and/or libelous material from being transmitted over the air. It does this by automatically delaying program material by up to 8 seconds, allowing time for the monitoring operator to make the decision as to whether the material being delayed fits into either category.

If objectionable material is heard, patented electronic circuitry allows all or a portion of the delayed audio to be "dumped" and the program resumed without interruption. The delay time is increased automatically and gradually after the "dump" occurs. A remote control option allows an external relay to be attached which would prevent uncontrolled sources, such as telephone callers, from being aired until the delay time is again long enough to provide protection.

The BD500 has some special functions to make it convenient to use: the WAIT AND EXIT function can be used to synchronize to a network or live signal feed, and the RAMP TO ZERO function can be used to decrease the delay time to 0.00 gradually after it is no longer needed for a safety margin.

This manual discusses the use and operation of the BD500. All of the functions are presented explicitly, which may make the manual seem somewhat forbidding. However, the unit is very simple to use and the apparent complexity portrayed in this manual is due to our desire to offer complete and accurate information.

BD500 Features:

- 8 seconds of stereo audio delay, configurable
- Allows multiple DUMP operations without exhausting the delay buffer. The DUMP function is adjustable and may be configured to delete an amount between 1.00 seconds and 8.00 seconds, programmable in half-second increments
- SNEEZE function replaces microphone mute switch and allows short interruptions to be unnoticeable
- Patented Eventide *Rebuild* (catch-up) provides fast recovery from a DUMP or SNEEZE while show is in progress
- 18-bit Analog to Digital and Digital to Analog converters
- 32000 samples per second sample rate
- Precision Fixed Delay mode which allows a front panel selectable delay between 2.25mS and 8 seconds in steps of 125uS.
- WAIT AND EXIT drops from full delay to 0.00 delay in 8 seconds
- RAMP TO ZERO reduces the delay slowly using the same patented Eventide process as Rebuild
- WAIT FOR SAFE function allows starting a show with a safe amount of delay
- Numeric display shows amount of delay
- Front panel configuration and display of audio input and output attenuation
- Remote control inputs to trigger SNEEZE and DUMP
- Relay contacts to signal safe condition and DUMP button actuation

Optional Features:

- AES/EBU digital audio input and output
- 48000 samples per second input and output sample rate
- RS-232 remote control
- Remote Control features including:
 - 7 programmable remote button inputs on rear panel connector including mute, station break insert and all front panel controls complete with permutations of those controls.
 - 4 programmable outputs to trigger relays, configurable to indicate different timing conditions including status of all processes, bypass mode, and error conditions.
- 8 delayed control signal lines used to delay external controls by the amount of the audio delay

Front Panel

See *Chapter 2* for in-depth explanation of the following controls, or look up individual terms in the Index.

The front panel buttons have indicator lights which are lit when a function is available. A flashing light indicates that the function is running. Pressing a button when it is flashing will cancel the function. The BYPASS button is illuminated when the unit is bypassed. The DUMP button is illuminated when the unit has enough delay to be safe. The CONFIGURATION button and configuration mode are intended to be used by an authorized operator only and thus its operation is intentionally less obvious. See *Appendix A* for configuration mode information.

Since the BD500 can serve as a broadcast profanity delay or as a precision fixed delay, many of the buttons have dual purpose. In addition some buttons serve in navigating the configuration menus (discussed in *Chapter 3*). All of the buttons are labeled for profanity delay operation.

1 BYPASS button

Toggles the unit in and out of *bypass*. While *bypassed* the LED is illuminated and the audio path through the BD500 is bypassed through a relay. Pressing this button while *bypassed* will put the unit *in-line*, with zero delay. This button is also used to exit from *configuration* mode.

2 CONFIGURE button

Enters *configuration* mode. See *Chapter 3*.

3 Level Meters

Two 10-segment LED bar graphs show channel 1 and 2 input levels. These graphs act as meters and may be used to align the equipment such that adequate audio levels are presented to the BD500.

4 WAIT FOR SAFE button

In *profanity delay* mode only, initiates or cancels the wait for safe mode which is used to start a show with a safe amount of delay.

5 WAIT AND EXIT button

In *profanity delay* mode only, initiates or cancels the wait and exit process which exits quickly from delay.

6 REBUILD button

In *profanity delay* mode, starts or stops rebuilding the delay. In *precision fixed delay* mode, decrements the current delay-amount digit.

7 RAMP TO ZERO button

In *profanity delay* mode, instructs the unit to start or stop ramping toward 0.00 delay. In *precision fixed delay* mode, this button increments the current delay-amount digit.

8 SNEEZE button

If the unit is configured as a profanity delay, this button is used to cut off microphone audio. If delay is greater than 0.00, the unit will reduce the delay while SNEEZE is held. In *configuration* mode, this button sets an individual value back to factory defaults. In *precision delay* mode, this button steps between digits of the delay-amount.

9 3-Character Display

The 3-character LED shows delay-amount values, text information, and configurable parameter values.

10 Delay-Amount Bar Graph

This 15-segment LED bar graph indicates current delay as a fraction of maximum delay or, in precision fixed delay mode, indicates which digit of the delay value is selected. This display is also used for visual cues during *startup* and *configuration* mode.

11 DUMP button

In *profanity delay* mode, deletes a segment of audio in order to stop an undesirable audio segment from being transmitted. This button is illuminated only if the unit is in *profanity delay* mode and then only if the amount of delay meets or exceeds a preset *safe* amount.

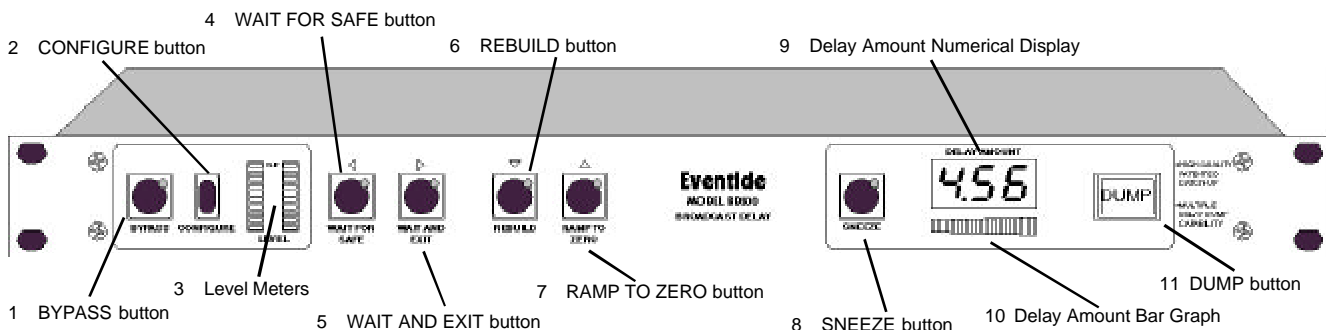

Rear Panel

AC Power Connection/Control

The AC connection is an integrated connector/switch/fuse holder to allow for greater reliability and safety.

1 AC Connector

IEC standard 3-prong connector. The center post is chassis ground. When power is not connected, the unit is bypassed, i.e., the audio inputs are connected to the audio outputs through a relay.

2 Power Switch

This controls the AC power into the BD500. When the power switch is off, the unit is bypassed.

3 Fuse Holder

1-Amp Slow Blow fuse. You should always replace it with the correct value. This fuse interrupts the AC power. Removal or destruction of this fuse will cause all operation to stop and will cause the bypass relay to close, connecting the XLR audio inputs to the XLR audio outputs. This does not guarantee that high voltage will not be present in the unit. Always disconnect the line cord from the AC connector before removing any cover or panel.

Standard and Optional Remote Control and Signalling

The BD500 has a standard remote control/signalling output. This allows remoting of the dump and sneeze functions and output of safe status (see Appendix B.) The optional remote control card (see Appendix C) allows RS-232 remote control, relay/dry contact remote control of front panel functions, relay drivers for external signals and lamps, and additional commands not available from the front panel.

4 RS-232 Connector (optional)

This is a female 9 pin DB9 connector supplied to connect a remote computer or terminal. The remote computer or terminal can control all functions of the BD500 including configuration. See Appendix E.

5 Remote Connector

This is a female 15 pin DB15 connector for connection of external signalling (buttons, indicators, telephone cut-off). See Appendices B and C.

6 Auxiliary Connector (optional)

This female 25-pin DB25 connector is used for delaying control signals by the delay amount. See Appendix D.

Optional AES/EBU - Digital Audio In/Out

These optional connections are used to connect professional digital audio gear to the BD500. These cables are differential with a shielded twisted pair.

7 Input data, XLR (optional)

The BD500's connector is female. Pin 1 is shield, 2 and 3 are differential.

8 Output data, XLR (optional)

The BD500's connector is male. Pin 1 is shield, 2 and 3 are differential.

Analog Audio Inputs and Outputs

XLR differential audio connections for two input channels and two output channels.

9 and 10 Channel 1 and 2 Outputs

Male XLR connectors.

11 and 12 Channel 1 and 2 Inputs

Female XLR connectors.

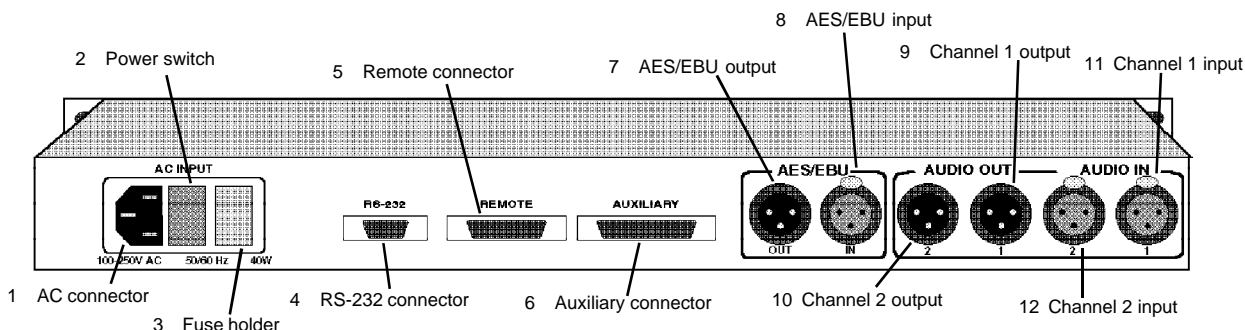

Audio Connections

The BD500 provides XLR differential audio connections for two input channels and two output channels. When bypassed, the audio pins of each input channel are connected to the audio pins of each output channel using a four pole relay. The unit is automatically bypassed when power is disconnected or turned off.

Analog Outputs

These male XLR connectors provide a differential balanced audio output with a maximum level of +4dBm and a nominal level of -20dBm. Pin 1 is grounded to the case of the external XLR connector. Pin 2 is +phase and pin 3 is -phase.

Each connection may also be used as an unbalanced line. The BD500's XLR analog audio output connectors are male. Pin 1 is grounded. Connect pin 2 to your center conductor and leave pin 3 floating.

Analog Inputs

These female XLR connectors provide differential balanced audio input. The input level has a maximum value of +4dBm and nominal level of -20dBm, but an internal attenuator increases the allowable level to 0dBm for nominal level and +24dBm for maximum. Pin 1 is grounded. Pin 2 is +phase and pin 3 is -phase.

Even though the inputs of the BD500 are balanced, you can still use them with an unbalanced line. The BD500 XLR analog audio input connectors are female. Pin 1 and pin 3 are grounded. Pin 2 is your audio signal.

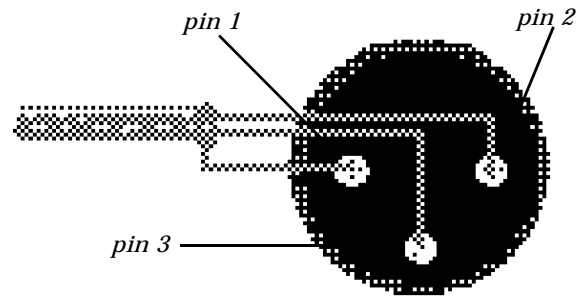

Male XLR output, balanced

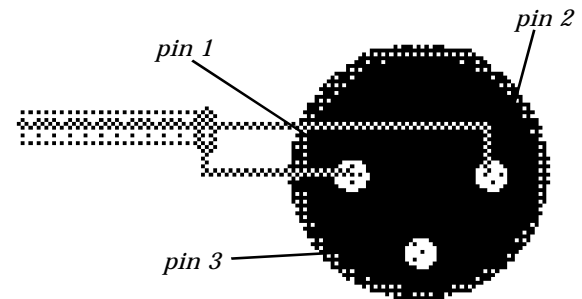

Male XLR output, unbalanced

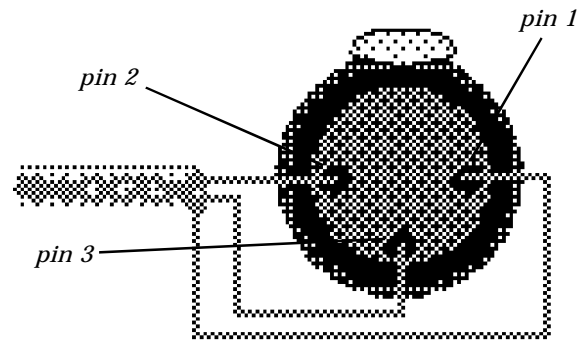

Female XLR input, balanced

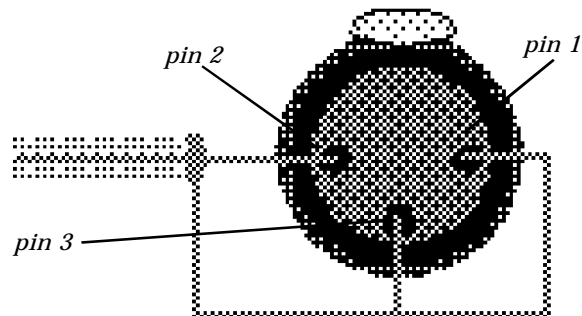

Female XLR input, unbalanced

Note: In the case of an XLR to XLR balanced line (i.e., differential) cable the shield should be left disconnected on one end (usually on the end connected to an instrument output). This helps to prevent ground loops.

Chapter 2 Operation

This chapter describes how the BD500 is operated from the front panel using factory default configuration values. Optional remote control and configuration are described in later chapters and appendices.

Installation

Rack Mount

Normally the BD500 will be mounted in a standard 19-inch rack using grommets to avoid damaging the front panel overlay. The BD500 should be supported at the rear. The rack should be well ventilated and in a dry and dust free environment so heat and moisture won't cause damage or degradation of performance.

Connect AC and Turn On Power Switch

Since the unit is electrically out of the audio path when in bypass mode, there is no reason to need access to the rear panel power switch. The power-up mode is selected by the configuration and is the same regardless of whether power is applied via the rear panel switch or via connecting the AC to an already switched-on unit. The unit may be left powered on even if the rack's power is to be disconnected.

Immediately after the unit is switched on, the front panel will be fully illuminated. After several seconds, the display will change to show $\epsilon 5 \epsilon$. Just before the $\epsilon 5 \epsilon$ symbol is displayed the unit flashes the software version number. The $\epsilon 5 \epsilon$ symbol is displayed for 15 seconds while the unit performs a test of it's audio processing hardware. After 15 seconds the unit will read the front panel buttons (and basic remote control inputs). If any buttons (except DUMP and SNEEZE) are pressed when the test cycle ends, the unit will perform a special start-up function (see *Appendix F*.) If no buttons are pressed, the unit will (by factory default) complete it's start-up. The display will show --- and the BYPASS button should be illuminated. This combination of LEDs indicates that the unit is powered on and in bypass mode.

Level Meters

There are two 10-segment LED bar graphs to display input level information. These graphs act as meters and may be used to align the equipment so adequate audio levels are presented to the BD500. The meters indicate the levels at the digital signal processor and are calibrated in decibels. The top LED is red. The next two are yellow, and the bottom seven are green. The red LED is lit if the level reaches clipping. The remaining LEDs indicate approximately -3dB, -6dB, -9dB, -12dB, -15dB, -18dB, -21dB, -24dB, -40dB.

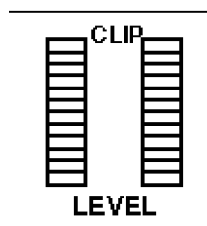

Connect Audio Inputs

Connect audio inputs to the two female XLR connectors on the rear panel. It is safe to connect and disconnect to the rear panel while the power is turned on. The inputs will probably come from a mixer board. Supply an audio source at a level just less than clipping. The BD500's level meters indicate input level. Adjust your audio source's output such that with a maximum input signal, the level meters have all of the green segments and both of the yellow segments lit, but not the red segment.

If your audio source cannot be adjusted or does not have the range to achieve a low enough or high enough signal, you must adjust the BD500's input trim. The BD500 has up to 48dB of input trim which is controllable from the front panel *configuration* mode. At the factory the input trim is set to unity gain. To add attenuation, press the BYPASS button once or twice to turn on the BYPASS button's LED. Now press the CONFIGURATION button to enter configuration mode. Next press the RAMP TO ZERO button to go up through the configuration levels until you reach *3RU*. Press the WAIT AND EXIT button twice to go to the INP variable. Now press SNEEZE to reset the parameter to the factory default *0db*. Press the REBUILD or RAMP TO ZERO buttons to step through the attenuation values to achieve the desired amount of trim attenuation or gain. The available range is -31dB (attenuation) and 17dB (gain). The trim adjustment affects the level meters as the adjustment is made. Note that since the unit is bypassed (not processing audio), the output level is not affected by this adjustment. The level meters will show the input levels as you make this adjustment.

Once the adjustment is complete, press the BYPASS button twice to place the unit in-line.

Connect Audio Outputs

The BD500 has an output level control, again operated from *configuration* mode, which can reduce the output audio by up to 40dB. The factory default is *no* attenuation.

To adjust the audio output attenuation, repeat the above process except choose the *out* variable instead. The range of this variable is -41 thru 0dB. Note that since the unit is bypassed (not processing audio), the output level is not affected by this adjustment. The unit will have to be placed on-line (press BYPASS twice) to test the new value.

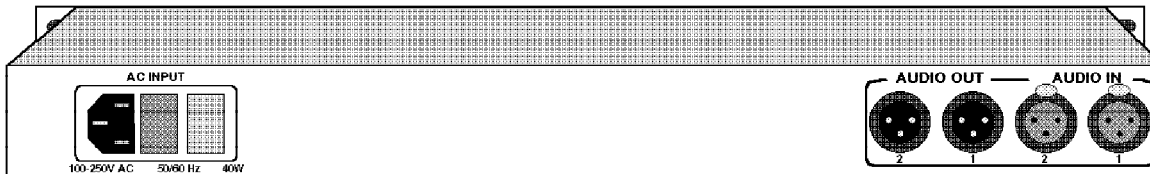

Understanding BD500 Profanity Delay Functions

This section uses the tape recorder profanity delay as an analogy to describe how the Eventide digital broadcast delay behaves when used as a profanity delay. The digital broadcast delay can be likened to a tape recorder with some new features. A basic tape recorder profanity delay would look like this:

When the delay is placed in line, the microphone (audio source) is connected to the record head while the transmitter is connected to the play head. This introduces a delay determined by the speed of the tape and the distance between the tape heads.

In our analogy the speed of the tape is constant. The distance between heads is measured in seconds and there is enough room between the tape heads for 8 seconds of delay. Factory default values are used whenever a time or duration is mentioned.

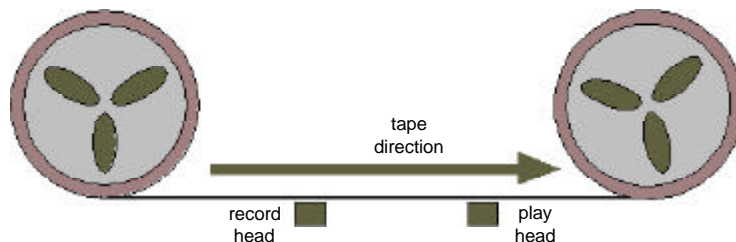

The Eventide system offers these features:

REBUILD - Increase the delay gradually

This feature allows the time between the play head and record head to be increased, in a subtle and transparent way. At the start the play head and record head overlap (no delay). The record head is slowly moved to the left until 8 seconds of delay exists. The Eventide patented rebuild process does this in about 120 seconds *without causing a pitch change* in the audio. Rebuild is used to recover from a dump, without having to go to a break.

RAMP TO ZERO - Decrease the delay gradually

This feature is similar to rebuild except that the record head is moved to the right, in a subtle and transparent way, again taking a few minutes. When the record head reaches the play head, the unit is at live. Ramp to zero is used to exit from delay when the call-in portion of a program is over.

WAIT FOR SAFE - Bring delay from 0 seconds to 4 seconds quickly

When the *wait for safe* process is started, the tape is bypassed so the transmitter gets live audio. The record head is moved to the left by 4 seconds. After 4 seconds of recording, the transmitter is reconnected to the tape delay. There is now a 4 second delay. Note, since the initial 4 second segment of audio will be repeated at the play head, it is up to the user to prevent the live audio from going over the air. This feature is used to start a show, coming from a network news feed, traffic report or other non-delayed program.

WAIT AND EXIT - Decrease the delay to 0 seconds quickly

This front panel feature is a method of quickly reducing the delay to 0.00 seconds. This process marks where on the tape the record head was when *wait and exit* is started. When that piece of tape reaches the play head, the record head is moved to the play head, decreasing the delay suddenly to 0.00 seconds. Use this command when a call-in show needs delay but where a break to non-delayed operation is required.

SNEEZE - Edit the delay before a bad noise happens

This feature is used to stop the record process temporarily. While the SNEEZE button is pressed, the record head moves toward the play head at the same speed as the tape, not recording any audio, until the SNEEZE button is released (at which point the record head stops), or until the record head reaches the play head, at which point the silence is recorded to the tape.

DUMP - Edit the delay after a bad noise happens

DUMP is used to edit several seconds of audio from the delay. Pressing DUMP moves the record head 3 seconds toward the play head (or up to the play head, whichever is less). This causes the most recent 3 seconds of audio from the microphone to be discarded.

See *Appendix C* for a description of optional Remote Control Connector features.

Operation as a Profanity Delay

The BD500 may be used as a broadcast profanity delay. This is its primary function and factory default mode.

When power is first applied to the BD500, the unit's audio inputs and outputs are bypassed through a relay. Pressing the BYPASS button places the unit in-line with 0.00 delay. If the audio levels are adjusted properly, there should be no perceptible difference in audio levels. Note that since the BD500 uses true relay bypass, there might be a slight click. The 3-digit display will now read 0.00 which indicates no delay. The red indicators on several of the buttons will be lit, indicating which are valid choices. Which indicators are lit changes depending on what state (or mode) the BD500 is in. Since the unit is at 0.00 delay and in-line it will be in live mode. The following is a list of the few different modes the unit may be placed in:

Modes

- *bypass* and *configuration* - delay is set to 0.00 seconds, relays bypass the audio directly from input connectors to output connectors.
- *static* - bypass relays are open (unit is in-line), delay is not changing.
- *rebuild* - bypass relays are open (unit is in-line), delay is slowly growing or is at maximum.
- *ramp to zero* - bypass relays are open (unit is in-line), delay is slowly reducing. Unit goes to *static* when it reaches 0.00 delay.
- *wait for safe* - bypass relays are open (unit is in-line), delay is filling with audio, but outputs are seeing input audio without delay. Unit switches to rebuild mode when *safe delay time* is reached.
- *sneeze* - bypass relays are open (unit is in-line), input audio is not going into delay, but output audio is coming from the delay. The delay length is reducing rapidly. When the SNEEZE button is released the unit will go back to the previous mode.
- *wait and exit* - bypass relays are open (unit is in-line), input audio is not going into delay, but output audio is coming from the delay. The delay length is reducing rapidly. The unit will go into static mode when it reaches 0.00 delay. The SNEEZE button is disabled.

Functions and Features

By default the BD500 is in *bypass* mode. Press the BYPASS button to put the BD500 in static mode. The delay is now at 0.00 seconds and there should be no perceptible difference between bypass and static mode. After delay build is initiated and until the delay is reduced back to 0.00, all audio must pass through the BD500 before going to the transmitter.

Starting a Show Segment with REBUILD

This process is used to start a show in a simple manner. The guest or dial-in caller is enabled in less than two minutes. The host customarily uses this period for an introduction or monologue.

As a show starts, the delay is set to 0.00. Pressing the REBUILD button starts a process by which the delay is slowly increased. During the rebuild process the REBUILD button's indicator will flash.

In less than two minutes (depending on characteristics of input audio) the BD500 will have enough delay built up to be 'safe' for a caller to be placed on the air. The DUMP button will light up to confirm this. The delay amount will show 4.00 and increasing. If configured, a rear panel output line will allow an external relay to be closed, enabling the phone line.

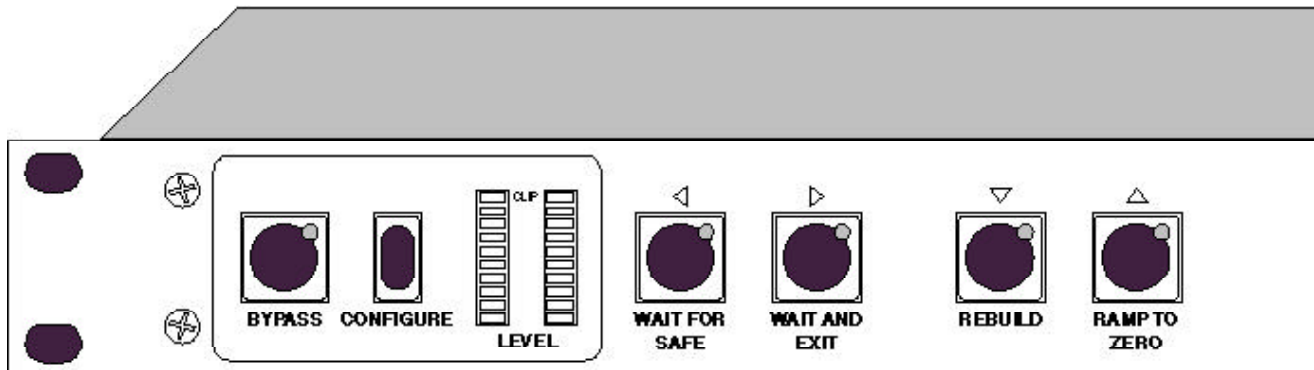

After a few minutes, the delay will reach maximum and the REBUILD button's indicator will turn off. The rebuild process is complete, but the delay remains in rebuild mode. This means that if SNEEZE or DUMP is used, after the SNEEZE or DUMP button is released, the delay will automatically rebuild back to maximum.

Starting a Show Segment with WAIT FOR SAFE

This process is used to start a show rapidly. The guest or dial-in caller are enabled immediately after the studio goes on-the-air.

Before beginning, the transmitter is not getting its source from the BD500.

- The operator needs to know, or to set, the configuration value of safe time (default is 4.00 seconds.)
- Safe time (or more) *before* the studio goes on-the-air the operator presses the WAIT FOR SAFE button.
- The host begins talking immediately.

When the DUMP button illuminates:

- The WAIT FOR SAFE process has completed.
- The SAFE relay output is enabled.
- The engineer or host fades the output of the BD500 into the transmitter. (see note below)
- The host may begin taking dial-in callers.

The BD500 drops into rebuild mode and slowly completes building up to maximum delay.

Note: During the 4-second period that *wait for safe* is running and the WAIT FOR SAFE button's indicator is flashing, the microphone audio is passed directly to the BD500 outputs. It is usually undesirable to have that audio pass over the air. Use a mixer or other control to disable that audio until the show is scheduled to start.

Ending a Show Segment with RAMP TO ZERO

This process gradually reduces the delay and takes a variable amount of time up to a few minutes.

During the show, the BD500 would usually remain in rebuild mode at maximum delay. Whenever SNEEZE or DUMP is used, the unit rebuilds back to maximum. To end the show, press RAMP TO ZERO. The delay will reduce in several minutes to 0.00 while the RAMP TO ZERO button's indicator flashes. During ramp to zero the DUMP and SNEEZE buttons will continue to be available, but an eye should be kept on how much time is actually still available to be dumped or sneezed away. To stop the ramp to zero process, press the RAMP TO ZERO button. The unit will go to static mode (delay not changing). The ramp to zero process may be resumed, or another function may be started.

Once the ramp to zero process is complete, the unit will operate at 0 delay.

Ending a Show Segment with WAIT AND EXIT

This process rapidly reduces the delay and takes 8 seconds or less.

At the end of the show, after the last word is spoken, press the WAIT AND EXIT button. All of the audio delayed in the BD500 is output until the delay reaches 0.00. The WAIT AND EXIT button's indicator flashes until the process is complete. Microphone audio is ignored by the BD500 during this process. When the delay reaches 0.00, the unit goes into live mode in which input audio is passed directly through the delay.

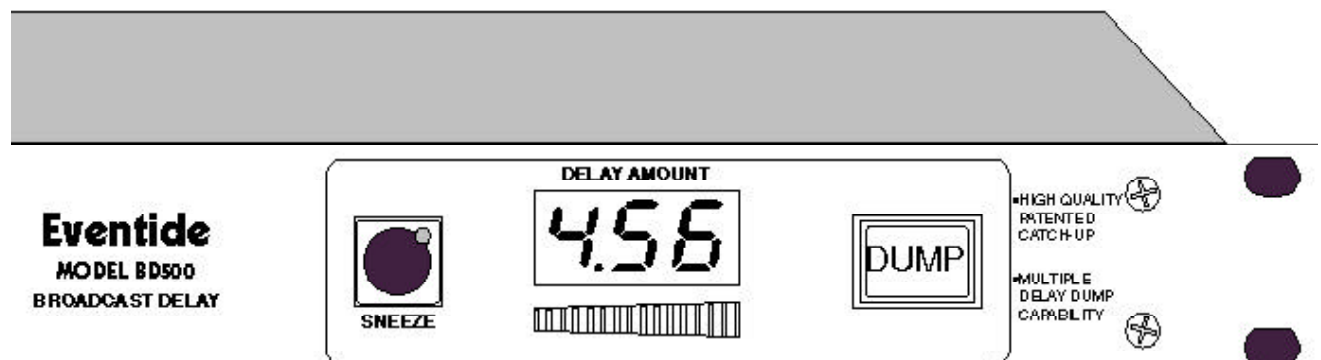

If the WAIT AND EXIT button is pressed erroneously, the process may be cancelled by pressing the WAIT AND EXIT button again. The unit will go back to the delay it had before WAIT AND EXIT was pressed and will be static (delay not changing).

DUMP Button

This button has several functions. The primary purpose of this button is to stop a profanity from going out over the air. This button is illuminated when *in-line* with a safe amount of delay (specified by *safe time*). Here is a list of modes and how the DUMP button works in each mode:

In rebuild or ramp to zero

DUMP causes the unit to delete several seconds (configurable) from the delay line including the audio information which has most recently been input to the delay line. The amount dumped is configurable and defaults to 3.00 seconds. When the DUMP button is pressed, the dump amount is subtracted from the current delay. If the displayed delay is lower than the dump amount, the delay is reduced all the way to 0.00. While the DUMP button is held down, the delay is held static. After DUMP is released, the unit continues with the previous mode. Note: Even if the unit is no longer rebuilding, having already reached full delay, the unit will still return to rebuild mode after DUMP is released.

In configuration

DUMP causes the unit to exit configuration mode and go into bypass mode.

In wait for safe

DUMP causes the unit to stop wait for safe, leaving the delay at 0 seconds.

In bypass, live, or wait and exit

DUMP has no function.

SNEEZE Button

This button is used to cover up an otherwise audible interruption to a program like a sneeze, cough, comment to the caller or engineer, or other undesirable noise.

If the unit is in-line (not bypassed) in profanity delay mode and not in wait for safe or wait and exit mode, this button will stop accepting input audio while it is held. The delayed audio will continue to be played out, reducing the delay amount. This would make the listener unaware that a mute occurred. If the delay reaches 0.00, or starts at 0.00, the audio is muted. When SNEEZE is released, the unit goes back to the interrupted mode.

Delay Amount Display

The display consists of a bar graph and a 3-digit numerical display. The numerical portion shows the delay amount in seconds with optional fractions of seconds. The factory default is to show seconds and hundredths of seconds with the decimal point appropriately placed. The bar graph indicates what portion of maximum the unit is delaying. For instance, if the unit is delaying at 3.50 seconds and the unit is configured to have a maximum of 8 seconds of delay, 6 of the 15 bar graph segments are lit.

The display is configurable to be blank, or to show 1, 2 or 3 digits of resolution of delay length. In bypass the display will show the safe time.

Operation as a Precision Fixed Delay

The BD500 may be used as a fixed stereo delay line, adjustable from 0.000 seconds to 8.000 seconds. Operation is straightforward with several front panel buttons serving secondary duty as fixed delay controls.

There are two ways to enter precision fixed delay mode. The easiest is to shut down the unit, then turn it back on holding down the REBUILD button. After the *ε 5ε* mode completes you will be prompted to select *PFd* or *bd*. The 2nd method is from *configuration* mode. Go into *bypass* mode. In *bypass* mode the display shows *- - -*. Press the CONFIGURE button. This puts the unit into *configuration* mode. Now press the RAMP TO ZERO button. You are now at the "on-line" configuration level. Now press the WAIT AND EXIT button twice. This moves across the on-line level to the *run* parameter. The display should now show *rUn*. Now press the WAIT AND EXIT button repetitively (stepping through run modes) until the display shows *PFd*. Press the BYPASS button to exit *configuration* mode. The display should show *- - -*. Now press BYPASS to put the unit in-line. The unit will be in *fixed delay* mode.

To return to *profanity delay* operation, press BYPASS, then CONFIGURE, then RAMP TO ZERO, then WAIT AND EXIT twice. The display now shows *rUn*. Now press SNEEZE to return to the factory default setting of the *run* parameter. Now press BYPASS to get out of *configuration* mode.

Controlling the Fixed Delay

In *precision fixed delay* mode the only operable buttons are titled BYPASS, REBUILD, RAMP TO ZERO, and SNEEZE. The buttons behave as follows:

- BYPASS takes the unit off-line Always valid.
- REBUILD decrements selected delay digit. Valid if lit.
- RAMP TO ZERO increments selected delay digit. Valid if lit.
- SNEEZE selects one of 5-sets of digits to be adjusted. Always valid.

The bar graph below the three digit display indicates which of seven digits (five sets) is selected for adjustment. The presence of the decimal point indicates that the three digits shown are the ones, tenths and hundredths digits. Press the SNEEZE button several times to step through the selected digits. The following illustration shows a 7.001625-second delay as the SNEEZE button is pressed five times.

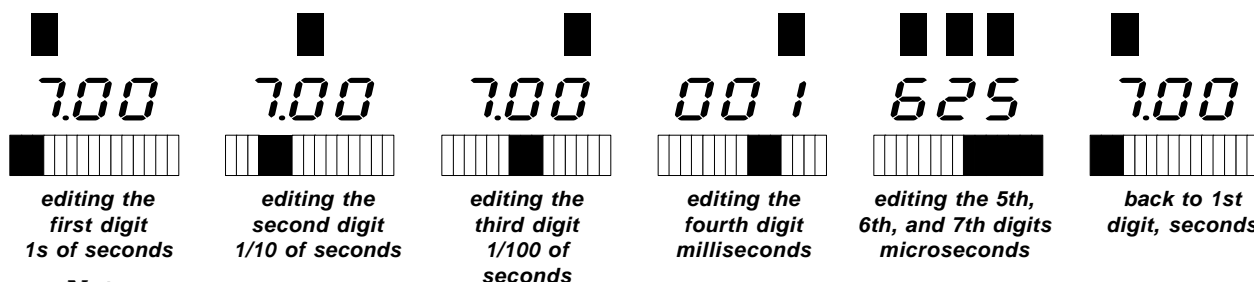

Usage Notes

The BD500 provides precision down to 4 samples in length. Thus at 48ksamples/sec you will see 4/48000 of a second adjustment precision, or 83.3microseconds. Thus if you move the last 3 digits up and down you will see changes that are around 83 per jump. At 32ksamples/sec you will see 125uS adjustment precision.

The minimum delay the BD500 will allow is also dependant on the sample rate used by the BD500. The minimum will be less than 5 milliseconds.

The fixed delay writes data continuously into the 8-second buffer. Changes in delay changes the position of the play head, not the record head. That means that, if the delay length is adjusted by ear, the user doesn't have to wait for new input audio to check the adjustment. While listening to an audio source, try adjusting the seconds digit upward. It is easy to play the same 1-second piece of input audio eight times.

Note: When entering precision fixed delay mode from bypass the delay buffer is set to the previous value used in the fixed delay. The delay line is erased, so the outputs will be silent for a brief time.

Chapter 3 Configuration

There are several adjustable values used by the broadcast delay. *Configuration* mode gives access to these values and allows them to be changed. This chapter covers the configurable variables that needed for the basic BD500. Configuration of optional features is covered in the appendices.

Operation of the configuration mode is via the front panel buttons. All of the buttons are used to navigate through a map of configuration variables. The WAIT FOR SAFE and WAIT AND EXIT buttons are used to move left and right across the map. The REBUILD and RAMP TO ZERO buttons are used to move up and down through the levels of the map and also to adjust the values of individual variables. The CONFIGURE button will move to the left side of the map and if pressed while already on the left side, will move up through the levels. The SNEEZE button is used to reset a particular variable to factory defaults.

See the side-bar for a map of the configuration parameters. *Note: Refer to Appendices for optional features.*

Basic Operation Example

From BYPASS, press CONFIGURE. The display changes to show *CONF*. Press the RAMP TO ZERO button to move up the map. The first press will move to *ION*. The next will move to *2t*. Now press the WAIT AND EXIT button a few times to move over to the *rt0* variable (ramp to zero time). Notice that the SNEEZE button's LED is not lit. This means that the *rt0* variable is set to the factory default. Use the RAMP TO ZERO button to change the value. Notice that the SNEEZE button lights up. Press the SNEEZE button to reset the parameter back to factory default.

Another Example

If the BYPASS button is not illuminated, press BYPASS. Next, press CONFIGURE. Once the display shows *CONF*, press the RAMP TO ZERO button. The display changes to *ION*. Now press the WAIT AND EXIT button twice. The display changes to *run*. To check the run mode, press the REBUILD or RAMP TO ZERO button. The display changes to show *LIU*, indicating go into live mode when exiting from bypass mode. To change the run mode, press the RAMP TO ZERO button. Use the REBUILD and RAMP TO ZERO buttons to go up and down through the four possible values for the run parameter.

Press BYPASS to exit from configure mode. Any changes made will remain until they are reconfigured.

Password Protection

If desired, configuration mode may be password protected. When protected, the user must press the CONFIGURE button and a single other button. The CONFIGURE button must be released *last*. When both buttons are released the unit will go into configuration mode. If the unit is password protected, the display will show *P--* when the CONFIGURE button is pressed. Change or enable the password using the *PAS* configuration variable.

Restoring Factory Defaults

All factory defaults may be restored by holding down the CONFIGURE button while power is turned on. Keep holding CONFIGURE down until the display shows "*RELEASE*". The "*RELEASE*" message text will be scrolled marquee-fashion across the display. Once CONFIGURE is released, the display will show "*FACTORY DEFAULTS*".

Individual config values may be set to factory default by using the SNEEZE button while the configurable is selected. The LED on the SNEEZE button is lit if the variable is *not* set to factory default.

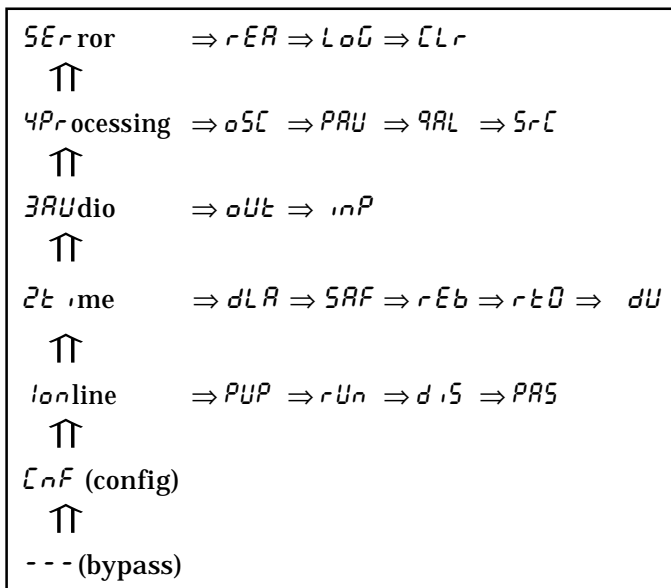

Table of Configuration Variables

Note: Full descriptions of the selectable values are available in pages following this table.

3 Character Identifier	Description	Units	Range of Values	Default Value
<i>cnf</i>	Start of Config Mode This selection has no configurable value. It indicates entry into configuration mode			
<i>pup</i>	Power-Up mode This option selects whether unit goes into bypass or in-line after power-up.	mode	<i>inL, bYP</i>	<i>bYP</i>
<i>run</i>	Run Mode This item selects the mode the unit goes into from BYPASS. Select <i>PFd</i> to enable precision fixed delay.	mode	<i>L iu, rEb, bFS, PFd</i>	<i>L iu</i>
<i>dis</i>	Display Digits This selects the number of digits used in profanity delay mode.	# of digits	<i>003, 02, 1, oFF</i>	<i>003</i>
<i>pas</i>	Password Allows a password to be selected which would limit access to the configuration mode.	button	<i>no, bYP, bFS, bPE, rEb, rt0, SnE, dU</i>	<i>no</i>
<i>dlr</i>	Delay Length Maximum length the profanity delay will rebuild to.	seconds	<i>100, 150, 200, ..., 750, 800</i>	<i>800</i>
<i>saf</i>	Safe Time Amount of time the profanity delay must have built up in order to be SAFE. Controls the lighting of the DUMP button and RCC outputs.	seconds	<i>100, 150, 200, ..., 750, 800</i>	<i>400</i>
<i>reb</i>	Rebuild Time Amount of time it will take to rebuild the delay from 0 seconds to maximum.	seconds	<i>40, 60, 90, 120, 180, 240, ..., 600</i>	<i>120</i>
<i>rt0</i>	Ramp To Zero Time Amount of time it will take to perform a ramp to zero from maximum to 0 seconds.	seconds	<i>40, 60, 90, 120, 180, 240, ..., 600</i>	<i>120</i>
<i>du</i>	Dump Amount Number of seconds of audio that will be dumped when the DUMP button is pressed.	seconds	<i>100, 150, 200, ..., 750, 800</i>	<i>300</i>
<i>inp</i>	Input Attenuation Amount of attenuation or gain used at the input of the delay.	decibels	<i>-31, -25, ..., -2, -1, 0db, 1, 2, ..., 16, 17</i>	<i>0db</i>
<i>out</i>	Output Attenuation Amount of attenuation used at the outputs of the delay.	decibels	<i>-41, -40, ..., -2, -1, 0db</i>	<i>0db</i>
<i>osc</i>	Oscillator and Pause, or Pause only If Pause only is selected, rebuild or ramp to zero progress is made only during periods of silence.	method	<i>P, o P</i>	<i>o P</i>

3 Character Identifier	Description	Units	Range of Values	Default Value
<i>PAU</i>	Pause Detection Level Audio level (below maximum level) that is recognized as silence.	decibels	-46, -43, -40, -37, -34, -31, -28, -25, -22, -19	-40
<i>QAL</i>	Quality Requested Requested performance quality. Lower numbers have more artifacts but faster catchup.	percent of maximum quality	0, 10, 20, 30, 40, 50, 60, 70, 80, 90, 100	70
<i>SrC</i>	Source For Processor Input Left/right mix of channels to be used in determining the best times to do audio processing during rebuild or ramp to zero.	channel	LEF, L I, CEo, r I, r iO	CEo
<i>rEA</i>	Fatal Error Reaction Selects what should happen if a fatal error condition develops. Options are hide the error (usually restarts the unit) or halt and show error.	action	H id, SHo	SHo
<i>LoG</i>	Display Error Log Shows last three unique fatal error messages	error code	Loo, Loo, Loo	none
<i>CLr</i>	Clear Error Log Erases error log to 000s. Select YES to erase log. Automatically falls back to NO.	action	no, YES	no

Note: Configuration for optional features is discussed in the Appendices. For optional audio features, see *Appendix A*. For optional remote control features, see *Appendix C*.

Configurable Variables

CLR Clear

This control erases the stored fatal error log. See *Appendix F*.

d15 Display Digits

This is the number of digits used to display the current delay amount. The BD500 has a three digit numeric display used to show the delay amount in hundredths of seconds. As the delay rebuilds or ramps to zero, the hundredths digit can change rapidly enough to be distracting to the operator. By changing the number of display digits to two, one or even none, this source of distraction can be reduced greatly or eliminated. Since the operator really only needs to know that the BD500 is in *rebuild*, and whether it is *safe* or not, the operator may choose not to have the delay time presented in such high resolution.

dLR Delay Length

Delay length controls the maximum length of the broadcast delay. This adjustment may select a delay length of from 2.00 to 8.00 seconds. Select a length allowing the operator to dump multiple offending phrases without impairing operator efficiency. A length which is too short will not allow the operator enough time to delete offending speech. A length which is too long increases the amount of time required to exit from the delay at the start of a break or end of a show.

dU Dump Amount

This is the amount of time deleted from the delay when the DUMP button is pressed. If the DUMP button is pressed when less than this amount of time is in the delay, then the entire delay is deleted.

INP Input Level

This controls an attenuator in the analog audio inputs of the BD500. The maximum level is 17dB (17dB of gain). The minimum level is -31dB (31dB of attenuation). While the meters immediately reflect changes to the input level configuration variable, this control can not affect levels seen at the analog outputs when *bypassed*.

LOG Error Log

This variable shows the last three unique fatal error messages. See *Appendix F*. 000 means no error recorded.

o5C Oscillator (or Oscillator and Pause)

This parameter controls the technique used to perform the rebuild process (and ramp to zero process). The default, oscillator and pause mode (o P), performs the fastest and best sounding rebuild for most kinds of audio material. The alternative, pause only mode (P), produces a very high quality rebuild for audio comprised solely of speech. This mode may rebuild slower than oscillator and pause mode under some circumstances and is not recommended for use if the input signal contains music, speech lacking pauses or audio containing constant high level background noise (car-phone audio or wind noise).

oUt Output Level

This controls attenuation in the analog and digital audio outputs of the BD500. The maximum level is 0dB (no attenuation). The minimum level is -41dB (41dB of attenuation). This control does not affect output levels when *bypassed*.

PAS Password

Where some modicum of security is needed, this value may be changed to the identifier of a front panel button. If set, a user would have to go to BYPASS, press and hold CONFIGURE, then press the selected additional front panel button, in order to get into configuration mode. A selection of no indicates not set.

PAU Pause Level Adjustment

This value sets the threshold level used for the detection of *pauses* or silence. The default value has been optimized for normal usage. It may be necessary to adjust this value if the level of ambient noise is high. Great care should be taken when adjusting this value, as setting the threshold too high or too low may impair the catchup operation. The effects of changing this setting are best observed while rebuilding in pause only mode. Generally, the lowest threshold level that allows for rebuilding to occur should be used.

PUU Power-Up mode

This controls whether the BD500 goes into bypass at power-up or goes directly into processing. If inL is selected, the unit will go directly to the in-line mode selected by the rUn configuration variable.

9AL Quality

This value governs the extent to which the configured rebuild and ramp to zero time may be deviated from in order to maintain high audio quality during rebuild. A setting of 100 percent produces the best-sounding audio, but allows the unit to deviate considerably from the configured times. The extent of the actual deviation depends upon the characteristics of the audio material being processed. If strict adherence to the configured time is required, the quality can be set to 0 percent. This is not a recommended setting though, as it will tend to produce poor audio quality during rebuild and ramp to zero. The default quality values should suffice for normal usage.

rER Reaction

This variable chooses what remedy the BD500 will use in case of a fatal error. The choices are *SHo* (show) or *Hid* (hide.) If *SHo* is chosen, an error message will be displayed until the user presses the DUMP button or removes power from the unit. If *Hid* is chosen, the unit will immediately reboot and start up again, after a short delay, resuming the operation that was interrupted by the error. In either case the error will be logged. See *Appendix F*.

rEb Rebuild Time

The rebuild time is how long the BD500 will need to build from 0.00 delay to maximum delay. This is used to start up the delay or recover from DUMP. The rebuild time affects the slowness of the audio material passing through the delay and is measured in seconds. The factory default is 120 seconds, or 2 minutes, for an 8-second maximum delay. The actual time to complete a rebuild may be longer, depending on the audio content, and the settings of several other configuration parameters.

rE0 Ramp To Zero Time

The ramp to zero time is how long the BD500 will need to go from maximum delay to 0.00 delay. This is used to exit out of the delay gracefully. The ramp to zero time affects the increase of speed of the audio material passing through the delay and is measured in seconds. The actual time to complete a ramp to zero may be longer, depending on the audio content, and the settings of several other configuration parameters.

rUn Run mode

This controls what mode the BD500 enters when leaving bypass mode. The selections are live, wait for safe, rebuild, and precision fixed delay. Each of these modes is described elsewhere in this chapter. The factory default is live.

5AF Safe Time

In many broadcasting situations a control output from the broadcast delay will be used to control a telephone connection or auxiliary microphone input. The control input is only connected when enough delay has been built up to allow the operator to delete offending vocals. The delay length which must exist to allow the audio connection is called the *safe time*. The safe time is related to the reaction time of the operator and the complexity of what would be called *offending* speech. Normally, the safe time is several seconds. Since wait for safe is used to quickly build the delay to an amount long enough to be safe, the *safe time* is also the time value used by wait for safe. The value displayed while in bypass is the *safe time*. This is important information for users of the wait for safe feature. The DUMP button is illuminated only when the delay is larger than safe time.

5rE Source

This selects the amount of signal from each channel that will be fed into the signal processor for use in determining best time-to-process. If the unit is unable to pick good times-to-process, artifacts will be introduced into the output audio. This value may be set to one of five values, from left to right, *LEF L I EEn r I r iG*. *LEF* indicates all of channel 1 and none of channel 2. *r iG* indicates all channel 2. *EEn* indicates an even sample of both. This adjustment does not affect the audio signal levels seen at the outputs.

If only one channel is used for input, set the source to that channel (*LEF* or *r iG*). If one channel is usually of poorer quality (i.e., a telephone), give the other channel priority. For instance, if channel 1 is the local microphone and channel 2 is telephone, you might select *L I*. If channel 2 is a mix of local microphone and telephone, and channel 1 is never used, select *r iG*.

Appendix A Optional AES/EBU Digital Audio

The digital audio option replaces the standard BD500 analog-only audio board. It provides two channel analog audio input and output, or two channel digital audio input and output using the AES/EBU format. This appendix describes the connection, operation, and configuration of a BD500 with the digital audio option.

Connection

These cables are differential with a shielded twisted pair.

Input data, XLR

The BD500's connector is female. Pin 1 is shield, 2 and 3 are differential.

Output data, XLR

The BD500's connector is male. Pin 1 is shield, 2 and 3 are differential.

Configuration

If the BD500 is equipped with the digital audio option the *SPR* and *FLB* variables will be available. The *SPR* (sample rate) variable selects whether the input will be AES/EBU or analog and if analog, which of two fixed sample rates will be used. The *FLB* variable selects what the unit does in the case that AES/EBU is selected and the AES/EBU clock signal is bad.

The sample rate variable is accessed by entering *configuration* mode, stepping to the *SRU* level using RAMP TO ZERO, then stepping right to the *SPR* variable using WAIT AND EXIT. Now use the REBUILD and RAMP TO ZERO buttons to choose a sample rate or AES/EBU as an input. The factory default for the *SPR* variable is *48*, indicating 48,000 samples per second.

The fallback variable is accessed by entering configuration mode, stepping to the *SER* level using RAMP TO ZERO, then stepping right to the *FLB* variable using WAIT AND EXIT. Now use the REBUILD and RAMP TO ZERO buttons to choose analog or unlock.

Operation

The BD500 with digital audio option will support three input modes. These are:

- Analog input at 32000 samples per second;
- Analog input at 48000 samples per second;
- AES/EBU digital audio.

Regardless of what input mode is selected there will be audio on both AES/EBU and analog outputs. The sample rate of the outputs will always be the same as the sample rate on the selected input. This applies both to the analog audio operating mode, where the sample rate is selected by the *SPR* configuration variable, and to the digital audio operating mode where the BD500 derives the sample rate from the input AES/EBU signal.

If AES/EBU is selected and there is no digital audio signal present, the unit will declare an out-of-lock condition. If the unit is *in-line* (not in *bypass*) and an out-of-lock condition exists, the 3 digit display will flash. If the *FLB* (fallback) variable is set to *ANA* (fall back to analog) then the analog input audio will be used. The analog input will be sampled at either 32000 or 48000, the sample rate chosen being whichever of the two rates is closer to the AES/EBU sample rate last received by the unit (or 32000 samples/second if no AES/EBU signal

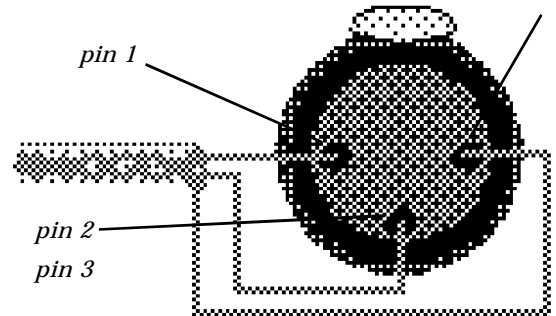
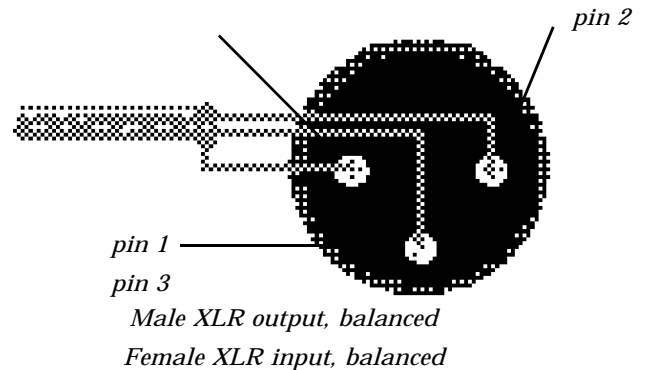

Note: In the case of an XLR to XLR balanced line

(i.e., differential) cable the shield should be left disconnected on one end (usually on the end connected to an instrument output). This helps to prevent ground loops.

has been present since power-up. The AES/EBU outputs will be active and the rate will be the same as the input analog sample rate. If the fallback variable is set to `unlock` the unit will mute the outputs.

Notes and Warnings for AES/EBU Operation

The input attenuation (`inp`) configuration parameter does *not* change the audio levels for AES/EBU inputs. The output attenuation (`out`) configuration parameter *does* affect AES/EBU outputs.

The AES/EBU source must be stable before putting the unit in-line. If your AES/EBU source's clock rate changes, or if the AES/EBU is disconnected, or if the AES/EBU audio source is turned off while the BD500 is processing audio (in-line and powered on), the BD500 may add artifacts to the audio, or may indicate a failure with an error message.

The BD500's purpose is to store audio and play it back with a delay. If the rate of audio into the unit changes while audio is stored, the audio played from the delay will change pitch. Thus if the AES/EBU source's sample rate changes or stops altogether (cable is disconnected), the BD500 may play out audio with a significant pitch shift! If the unit falls back from AES/EBU to analog input at a different sample rate there will be a pitch change in the audio already delayed through the unit. Your digital system must be set very close to either 32000 or 48000 samples per second or using the fallback option in the BD500 will allow several seconds of pitch changed audio to pass.

If the AES/EBU clock rate changes drastically the BD500 may drop some audio, even while at 0 delay. If this happens many times over a short interval, the BD500 will assume that something is wrong with the hardware and will display an error message. If the clock rate goes over 48000 samples per second the unit will display a message that scrolls across the display with the text "CLOCK ERROR."

Appendix B Basic Remote Control

The BD500 with the basic remote control feature has inputs for DUMP and SNEEZE and outputs to indicate safe and dump.

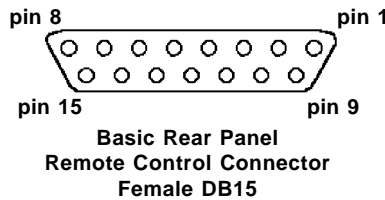

Remote Connector

The remote control connector is a female 15-pin DB15 on the rear panel.

Outputs

There are two conditional outputs available via the basic remote control outputs. These are safe, and DUMP. The position of the dump push button is monitored by a set of double-throw contacts (S.P.D.T.). The safe condition (whether there is a safe amount of delay accumulated or not) is monitored by two sets of double-throw contacts (D.P.D.T.).

Inputs

There are two input controls. These have identical function to the SNEEZE and DUMP buttons. The BD500 presents both contacts of the coil of an internal relay to the remote connector. The user provides five volts (nominal) across the contacts to close the relay and actuate the function, just as if the front panel button was pressed.

Pin-Outs

pin 1	dump-output, normally closed contact
pin 2	dump-output, common contact
pin 3	dump-output, normally open contact
pin 4	DUMP input, + side
pin 5	DUMP input, - side
pin 6	ground
pin 7	SNEEZE input, + side
pin 8	SNEEZE input, - side
pin 9	source of 100mA @5v for use in triggering DUMP and SNEEZE <i>only</i>
pin 10	safe-output 1, normally closed contact
pin 11	safe-output 1, common contact
pin 12	safe-output 1, normally open contact
pin 13	safe-output 2, normally closed contact
pin 14	safe-output 2, common contact
pin 15	safe-output 2, normally open contact

Notes:

- Relay contacts are rated 30V, 1A maximum.
- DUMP input and SNEEZE input are relay coils and are rated 180ohm, 3.75V to 7.5V.

A simple circuit for triggering DUMP:

Connect your push-button across pins 9 and 4. Short pins 5 and 6.

Configuring Optional Rear Panel Inputs and Outputs

The remote control feature supports up to 7 inputs and 4 outputs which may be connected to switches and relays. Using *configuration mode*, the inputs may be used to operate all of the front panel button functions and a few other functions as well. The assignment of the input lines to various commands is handled by the configuration mode. The remote outputs are also configurable to signal many different conditions in the BD500.

If the remote control option is installed the configuration mode will have an additional level of configurable items. This will be the $\delta r \text{E}$ level. To access this level go into configuration mode as described in chapter 3 and move up the levels using the RAMP TO ZERO button until the $\delta r \text{E}$ level is reached. Now use the WAIT AND EXIT and WAIT FOR SAFE buttons to navigate across the level. You will have the option of configuring the seven input signals and the four output signals.

Each configurable input may be configured to actuate one of several commands in the BD500. Similarly the outputs are configurable to be actuated when one of several conditions occurs in the BD500.

Note: U is represented by \cup , W is represented by \mathcal{W} , and V is represented by \cup .

Input Signals

The commands the inputs may be configured to are:

- oFF Off causes input signal to have no function (factory default)
- bYP Bypass same as the BYPASS button
- $\mathcal{C}nF$ Configure same as the CONFIGURE button
- WFS Wait For Safe same as the WAIT FOR SAFE button
- WAE Wait And Exit same as the WAIT AND EXIT button
- rEb Rebuild same as the REBUILD button (used in precision fixed delay as decrement)
- $r\text{t}0$ Ramp To Zero same as the RAMP TO ZERO button (used in precision fixed delay as increment)
- SnE Sneeze same as the SNEEZE button (used in precision fixed delay as digit select)
- dU Dump same as the DUMP button
- $L\text{iv}$ Live cancel all commands and go to 0.00 delay
- StA Static cancel all commands and hold at current delay
- FUL Full Delay cancel all commands and go to full delay
- MUt Mute momentary audio output mute.
- $Sb\text{r}$ Station Break Insert mutes the outputs while save the audio into the buffer. When the buffer reaches 4 seconds this mode ends and the unit goes into *ramp to zero* mode.
- $r\text{t}b$ Ramp To Bypass
- $d-r$ Dump into Rebuild dump and then force rebuild mode.
- $E-r$ Wait and Exit/Rebuild Toggle between wait&exit and rebuild
- $\cup-r$ Ramp to Zero/Rebuild Toggle between ramp to zero and rebuild

Input Explanations

The Bypass, Configure, Wait For Safe, Wait And Exit, Rebuild, Ramp To Zero, Sneeze, and Dump selections are identical in function to the front panel buttons. A closure on one of these inputs will duplicate the front panel operations. Only if a button on the front panel is actually depressed will these commands be overridden. These closures also perform the same operation in precision fixed delay mode as the front panel buttons of the same name.

There are additional functions available via these inputs that are not available on the front panel. These are described below.

Input Commands not available via front panel

Static This command cancels the current function. This puts the unit in a mode that is the same as if the RAMP TO ZERO button were pressed while the unit was ramping to zero. This command has no function in *precision fixed delay* mode.

Full Delay	This commands the unit into <i>static</i> mode at full delay. This command has no function in <i>precision fixed delay</i> mode.
Mute	This command will mute the output audio while the closure exists. Note that the unit will go into <i>mute</i> mode during this time so any button illumination or output signal that reports on a particular mode will report mute mode instead of the previous mode, even if the BD500 is still performing the previous function. When mute is no longer asserted the unit returns to the previous mode.
Station Break Insert	mutes the outputs while save the audio into the buffer. When the buffer reaches 4 seconds this mode ends and the unit goes into <i>ramp to zero</i> mode.
<i>These three special Remote Control features are supplied to allow maximum control with the minimum number of buttons.</i>	
Ramp To Bypass	performs a <i>ramp to zero</i> but when the unit reaches 0 delay it goes directly into <i>bypass</i> .
Dump into Rebuild	performs a dump and then goes into <i>rebuild</i> , regardless of the previous mode. This operation has no affect in precision fixed delay mode. If the delay is already 0, then the unit still goes into <i>rebuild</i> .
Wait and Exit/Rebuild	If the unit is at zero delay, this command puts it into <i>rebuild</i> mode. If the unit is not at zero delay, this command puts it into <i>wait and exit</i> mode.
Ramp to Zero/Rebuild	If the unit is at zero delay, the unit is placed into <i>rebuild</i> mode. If the unit is not at zero delay, the unit is put into <i>ramp to zero</i> .

Output Signals

The output signals may be configured to:

- *oFF* Off always high impedance (factory default)
- *oN* On always a closure to ground
- *bYP* Bypass closure to ground when *bypassed*, high impedance if in-line
- *Li* Live closure to ground when in-line and at 0.00 delay
- *WFS* Wait For Safe closure to ground when doing *wait for safe*
- *FUL* Full Delay closure to ground when at full delay, high impedance when delay < full
- *SARF* Safe closure to ground when > than safe time, high impedance when < safe time
- *WAE* Wait And Exit closure to ground when doing *wait and exit*
- *rT0* Ramp To Zero closure to ground when doing *ramp to zero*
- *rBn* Rebuild Mode closure to ground when in *rebuild* mode (doing rebuild, or at max). Note: During sneeze or mute, the unit will still be rebuilding and will return to rebuilding when mute or sneeze is released but this output signal will be off.
- *rEb* Rebuild closure to ground when doing *rebuild* (not at max delay). Note: During sneeze or mute, the unit will still be in *rebuild* mode and will return to rebuilding when mute or sneeze is released but this output signal will be off.
- *Mute* Mute closure to ground when mute is being operated.
- *dNP* Dump closure to ground when dump is being operated.
- *UnL* Unlock closure to ground when AES/EBU is selected as an input but no digital audio signal is present on the inputs. (requires optional digital audio card)
- *Sbi* Station Break Insert closure to ground when a station break insert is in progress.
- *rDY* Ready closure to ground indicates the unit is in run-time with the rear panel inputs ready to accept a command to adjust the delay length or go in or out of BYPASS.
- *Err* Error closure to ground indicates there is an error message in the Error Log
- *All OK* All Is OK closure to ground indicates there are no errors in the Error Log and the unit is in run-time with the rear panel inputs are ready to accept a command to adjust the delay length or go in or out of BYPASS.

Example, Wiring an External DUMP Button and Caller Cutoff Relay

This example connects a remote DUMP button to input 1 and connects a caller cutoff relay to output 1 and then configures the port to enable the external connections.

Hardware

The first step is wiring the hardware. *This section should be taken as an example only and proper design of the circuits described herein should be performed only by qualified personnel.*

Following the diagram shown below, connect a relay across pins 1 and 6 of a user supplied DB15 male connector. Additionally, connect pin 1 to pin 8. This will be the remote caller cutoff relay. The relay should have a coil resistance of about 1000 ohms with a pickup voltage of 12 volts, and a dropout voltage of 10 volts or less. The relay's contacts should have current, voltage, and leakage ratings to suit your system requirements. The relay coil will actuate when the BD500 is *safe*.

Connect your remote DUMP switch across pins 1 and 2. The switch should be normally open.

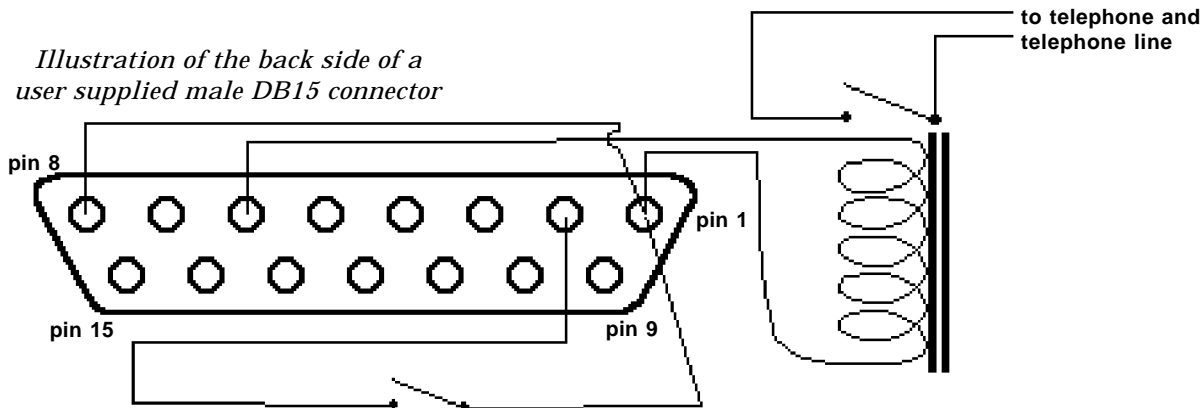

Configuration

This sequence will enable the remote DUMP button input and the caller cutoff relay.

- Make sure unit is in bypass mode (BYPASS button illuminated)
- Press the CONFIGURE button to enter *config* mode. The display shows *CONF*.
You are now in configuration mode
- Press the RAMP TO ZERO button six times so the display shows *ERR*.
You are at the remote control configuration level
- Press the WAIT AND EXIT button once to move to the first input item. The display shows *in 1*.
You are configuring remote input 1
- Press the RAMP TO ZERO button repetitively until the display shows *dU*.
You have set remote input 1 to emulate the DUMP button when triggered.
- Press the WAIT AND EXIT button repetitively until the display shows *ou 1*.
You are configuring remote output 1
- Press the RAMP TO ZERO button repetitively until the display shows *SRF*.
You have set remote output 1 to be a closure to ground when the unit is safe
- Press the BYPASS button so the BYPASS button illuminates
Configuration is complete; you are back in bypass mode

Testing

Press the BYPASS button to put the unit in-line. Now press WAIT FOR SAFE. The unit will quickly attain the *safe* condition. When the BD500's front panel DUMP button illuminates, the relay should close. Once this happens, press your new remote DUMP button. The delay should be reduced by the dump amount.

Appendix D Optional Auxiliary Connector for Control Signal Delay

Auxiliary Connector

This is a 25-pin female DB25 connector which is implemented as an eight channel control signal delay line. Signals presented to the auxiliary inputs are delayed by the displayed delay amount and driven to the auxiliary outputs.

Outputs

The eight outputs are open collector drivers. Each can sink 200mA, all outputs driven.

Inputs

The eight inputs are read at 2mS intervals.

pin 1	field contact supply output, 100mA max at a nominal voltage of 11.3v (see note) (pin 14 = ground).	pin 13	reference supply input for open collector output drivers, max 25v @ 1.6amps (pin 25 = ground)
pin 2	auxiliary input 1	pin 14	common ground for inputs
pin 3	auxiliary input 3	pin 15	auxiliary input 2
pin 4	auxiliary input 5	pin 16	auxiliary input 4
pin 5	auxiliary input 7	pin 17	auxiliary input 6
pin 6	no connection	pin 18	auxiliary input 8
pin 7	no connection	pin 19	no connection
pin 8	no connection	pin 20	no connection
pin 9	auxiliary output 2	pin 21	auxiliary output 1
pin 10	auxiliary output 4	pin 22	auxiliary output 3
pin 11	auxiliary output 6	pin 23	auxiliary output 5
pin 12	auxiliary output 8	pin 24	auxiliary output 7
		pin 25	common ground for open collector driver outputs (pin 13 = voltage)

Notes:

- The field contact supply output is a BD500 supplied voltage to be used to trigger the BD500's auxiliary inputs. This would be used for one side of a dry contact (switch or relay), the other side of which would go to one of the BD500's auxiliary inputs. This supply could also be used as the pull-up voltage for low current relays. This is a separate supply from the *remote* port supply.
- The reference supply input must equal the pull-up voltage for the open collector outputs. An inactive auxiliary output must be externally pulled up to this supply voltage. An active auxiliary output is pulled to ground by the BD500. The reference supply input is used for the internal clamp diodes.
- Auxiliary inputs will be off if set to ground or floating, and on if a voltage greater than 4.5 volts is present. The input impedance is 3Kohms so the source must supply about 1mA at 4.5 volts DC or more in order to signal an ON. The maximum input voltage is 25volts.

Appendix E Optional RS-232 Control

An option-card equipped BD500 can be completely configured and operated from a personal computer or user-supplied custom control system. The female 9 pin RS-232 connector on the rear panel is the mate for a typical office-type desktop computer. The BD500 operates as modem equipment. A straight through cable may be used to connect the BD500 to a unit operating as data terminal equipment, such as a personal computer.

The characteristics of the RS-232 connection are 9600 baud, 8 bits, 1 stop bit and no parity (9600, 8, 1, none).

The following table is the pin number, label, and direction relative to the BD500. The label is the same as used by the terminal or PC that will be connected to the BD500. Since the BD500 is 'modem equipment,' the labels and direction are opposite in meaning.

Pin 1	DCD (out)
Pin 2	RxData (out)
Pin 3	TxData (in)
Pin 4	DTR (in)
Pin 5	Gnd
Pin 6	DSR (out)
Pin 7	RTS (in)
Pin 8	CTS (out)
Pin 9	RI (out)

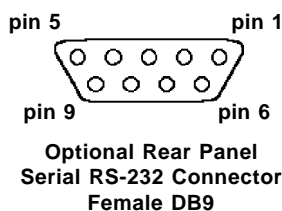

The BD500 only sends messages as a response to a poll from a host computer. The host computer must not send a message unless it has received a > character (hex 3E) or unless it has not heard from the BD500 in 100mS. An overflow or bad message will be answered with a E> (hex 45, 3E).

Protocol

The following page has a list of single byte commands which are available to the host computer. The table lists the response generated by the BD500. All commands will generate a response. !> indicates command processed, X> indicates command not valid at this time, E> indicates serial port error or unrecognized command, U> indicates front panel button was held down (or rear panel input signal is simulating a button) and message was ignored. Redundant commands will be answered with a good response. *End of sneeze* and *dump* will put the unit back in the mode it was in before the *sneeze* or *dump* started. All transmitted and received bytes are between 30hex and 5Fhex.

Protocol notes

The unit is allowed to send an error message (E>) at any time. Any interrupted message is terminated when the error message is sent, so the > character will be permission for the external device to send a new command.

The unit always gives a U> error message if a message is sent to the unit while a button is held down. The only way 'request mode' will respond with S <*sneeze*> is when the sneeze was instigated by RS-232 remote control.

A change in either the *DLA* or *RUN* configuration variables will have no effect until the unit goes from bypass to in-line.

The BD500 does not use the hardware control lines. Only RxData, TxData and Gnd are necessary.

RS-232 Protocol

- 0 requests *static* at 0 delay puts the unit in-line. If broadcast delay, puts the unit at 0 delay. If PFD goes to last delay.
- 1 increments PFD digit Note: PFD must be entered via configuration change to the run mode parameter (run).
- 2 decrements PFD digit
- 3 selects PFD digit
- 5 starts *mute* use the K command to unmute. Works in PFD and broadcast delay.
- 6 initiates *pause* use in broadcast delay from *live* to insert station identification.
- 7 initiates *ramp to bypass* in broadcast delay performs *ramp to zero* and then automatically switches to bypass.
- A initiates *wait and exit*
- B switches to bypass mode
- C requests config values shows current settings of each of the config values. This long response includes multiple records. Each record consists of a 3 byte config variable name, followed by an ASCII equal sign (=), followed by a 3 byte config value, followed by hex 0D (carriage return). After the last record will be an a >. None of the 3 byte values contain >. The records correspond to configuration items described in chapter 3 and are all ASCII characters of the set 0 through 9, A through Z, space and dash. Records which have no configurable values will have "NA " (3 bytes) instead of the 3 byte value.
- D performs a *dump*
- E entire config table dump entire config table, all variables, all available values. This long response includes multiple records. Each record consists of a 3 byte config variable name, followed by an ASCII equal sign (=), followed by one or more 3 byte strings, each containing config values, separated by spaces, followed by a space and then hex 0D (carriage return). After the last record will be a >. None of the 3 byte values contain >. The records correspond to configuration items described in *Chapter 3* and are all ASCII characters of the set 0 through 9, A through Z, space and dash. Records which have no configurable values will have "NA " (2 bytes and a space) instead of 3 byte strings.
- F go to *static* at full delay
- G go to next config variable steps to next config value. Responds with normal !>. Use X to request current config variable name and value. See also C, E, J, N, Q, V, X, and Y commands.
- H go to *static* at current delay If in broadcast delay mode goes to in-line, static and at full delay.
- I requests debugging info responds with machine state name and current delay amount. This is for debugging only, may change, and is redundant with the M and T commands.
- J store config variable write the current config variable's value into permanent storage.
- K ends a *sneeze*
- L requests levels three character response is left channel level followed by right channel level and terminated with >. Levels are reported using one digit ASCII hex of range 0 through 9, and A. Example: 25> is left channel level of 2, right channel of 5.
- M requests mode response is three characters of the form !n> where n is the current mode. Modes are A <*wait and exit*>, B <*bypass*>, D <*dump*>, G <*gapless*>, H <*static*>, L <*live*>, M <*mute*>, P <*precision fixed delay*>, R <*rebuild*>, S <*sneeze*>, W <*wait for safe*>, Z <*ramp to zero*>. Note: zero delay and maximum delay are not modes; if the unit reaches maximum delay while in rebuild mode, the unit remains in *rebuild* mode; though if the unit reaches zero delay it switches to static mode.
- N next config value steps the current config variable to the next value. Responds with normal "!>". This command does not change the stored config value, only the used value. Use the J command to save the current config variable. Use X to request current config variable name and value. See also G command.
- P requests PFD delay six character response is four digit decimal ASCII value of delay in milliseconds, followed by position indicator (1, 2, 3 or 4), followed by >. Note: This does not change the mode to PFD.
- Q resets config stepping points at start of config mode. Used with C, E, G, J, N and V, X, and Y commands to make configuration changes to the BD500.
- R initiates *rebuild*
- S starts a *sneeze* See K command for end-sneeze.
- T requests current delay four character response is three digit decimal ASCII value of delay in 10s of milliseconds, followed by >.
- U requests current delay/hex send delay amount in hexadecimal using 3 characters of ASCII/hex followed by >.
- V Eventide Factory Defaults request factory defaults for all config variables. Note: Allow 400mS before "!>"
- W initiates *wait for safe* Note: when the unit reaches safe, it will switch to rebuild mode.
- X examine config gives current config variable and value. Responds with an 8-character message consisting of a three character config variable identifier, an ASCII equal sign (=), the three character value of the config variable, and a >. See G, N and Q.
- Y first value sets the current config variable to the first value. Useful for making automated configuration changes. See C, E, G, J, N, Q, V and X commands.
- Z initiates *ramp to zero*

RS-232 Command Examples and Tables

This section offers organizational information and help information for using RS-232 commands.

Broadcast Delay Commands

These are the broadcast delay commands. Note that some commands will work in broadcast delay mode but are not commonly used are left out of this section.

- L** requests levels
- M** requests mode
- T** requests current delay
- U** requests current delay/hex
- 0** go to *static* at 0 delay
- H** go to *static* at current delay
- B** switches to bypass mode
- W** initiates *wait for safe*
- A** initiates *wait and exit*
- Z** initiates *ramp to zero*
- R** initiates *rebuild*
- S** starts a *sneeze*
- K** ends a *sneeze*
- D** performs a *dump*

Precision Fixed Delay Commands

These are the fixed delay commands.

- L** requests levels
- B** switches to bypass mode
- 0** switches from bypass to in-line
- 1** increments PFD digit
- 2** decrements PFD digit
- 3** selects PFD digit
- P** requests PFD delay value

The RS-232 commands allow the front panel of the BD500 to be completely replicated in function (and in form) by a remote device. A computer with a terminal emulator may use these commands to prove that all of the information and control is available. Use the T, M and P commands to watch modes and delays change as commands are issued.

Configuration Mode Commands

The RS-232 configuration commands step through the configuration variables in much the same way the front panel does. Use the G command to step to the next variable. Use the N command to step through values for a single variable.

Variables are not saved into nonvolatile memory immediately as is the case with the front panel *configuration* mode. You must use the J command to implicitly save a new value. Non-saved values are lost if the unit is powered off. Most values will, however, be used by the BD500 immediately after changed. Exceptions to this are the *rUn*, *dLR*, *SRF*, and *SPr* variables that, when changed, might cause bad artifacts in the audio. Changes to those variables are not used by the BD500 audio processor until the unit goes into and out of 0 delay or bypass.

- M** requests mode
- B** switches to bypass mode
- 0** switches from bypass to in-line
- C** dump values for all config variables
- E** dump possible values for all variables
- G** go to next config variable
- J** store current config variable in nvRAM
- N** next value for this variable
- Q** back to first variable
- V** Eventide Factory Defaults
- X** examine current variable
- Y** first value for this variable

Example configuration operations

Note that you must wait for a prompt before sending each character.

To change the rebuild rate from whatever it happens to be to 240, you can send Q G G G Y N N N N N J. Spaces are not used. This sequence says: go to first variable, then step through the variables to the REB variable, then set it to the first value, then step through to the 6th value which is 240, then save it.

In order to change the full delay amount the unit has to be placed into bypass. This sequence will change the maximum delay to 4 seconds and put the unit back in line. Q G G G Y N N N N J B 0 Note that if you issue the B command while the unit is already bypassed, you will get an error message. Your sequence may expect the error message and ignore it.

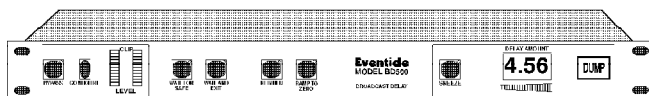

Appendix F Diagnostics

The BD500 has software features designed to aid debugging the system hardware. Some of these features may be used to assist in analyzing end-user setup problems or in diagnosing user or off site technician serviceable components. This section includes a breakdown of different operations that the broadcast delay does during power-up and while changing operation modes. In addition, the 'hidden' start-up modes and system hardware failure messages are described.

Disclaimer: This information is correct at the time of this manual's publication (before release of version 2.5 of the BD500 software.)

Start-up Sequence

- Reset front panel (turns all lights on)
- Turn off DS113 motherboard LED, then flash it on, then off again
- Turn off option board Remote Control Connector and Auxiliary Connector outputs
- Turn on DS113
- Cycle through the seven motherboard status LEDs from #2-0 to #2-6
- Turn off DS113
- Test the firmware ROMs - if fail, flash motherboard status LED #2-0 indefinitely - if pass, light motherboard status LED #2-0 indefinitely, then scan the rest of the LEDs once - the front panel will stay all-lights-on indefinitely if failure
- Test the motherboard RAM - if fail, flash motherboard status LED #2-1 indefinitely - if pass, light motherboard status LED #2-1 indefinitely, then scan the rest of the LEDs once - the front panel will stay all-lights-on indefinitely if failure
- Initialize motherboard RAM
- Flash motherboard status LEDs #2-4, #2-5 and #2-6 three times quickly, leaving them off
- Turn on DS113 motherboard LED
- Declare that we are not in run-time mode for Remote Control Connector status outputs
- Begin "STARTUP"
- Initialize Remote Control Connector outputs, *not* in run-time.
- Set audio bypass relay (redundant)
- Initialize RS-232 connector on option card.
- Initialize front panel (turns off DUMP light, meters and delay bar graph) - after this point diagnostics may be displayed on the front panel if a failure occurs (may be disabled in *configuration*)
- Display version message
- Check that motherboard memory was initialized.
- Check if unit has jumper for production self test - if yes, begin "TEST FIXTURE" and run test fixture forever
- Initialize AtoD converter used to measure power supply voltage.

- Put up "t5t" message.
- Check power supply voltage. If measures out of range, display error message.
- Check and load the battery backed memory configuration values.
- Initialize all configuration values (delay amount LEDs run all over the place during this process). If a reorganization of the configuration values is required (due to software upgrade) set all values to factory defaults here.
- Check if user is holding WAIT AND EXIT button - if so, put up "rELEASE" message and turn off 'hide fatal error mode', then resume.
- Test and initialize DSP coprocessor and audio section.
 - check for presence of DSP coprocessor.
 - init audio section.
 - upload coprocessor OS
 - test DSP coprocessor to main processor communications
 - upload 1st memory test to coprocessor, test communications, then run test.
 - upload 2nd memory test to coprocessor, test communications, then run test.
 - using results of 2nd memory test, set memory size
 - upload coprocessor OS for the 2nd time and test communications.
 - check analog clocks.
 - load and find version numbers of PFD and profanity delay coprocessor firmware
 - set up input and output level controls on coprocessor.
- Check if user is holding any button besides DUMP and WAIT AND EXIT and SNEEZE
 - If so, display "rELEASE" message.
 - If user was holding CONFIGURE, display "FRC - t0rY dEFaults", reset factory defaults and then continue with startup.
 - If user was holding BYPASS, display "tESt5", and then proceed into the production self-test system (this will fail if loopback cables are not installed, but not before testing RAM, EPROM, NVR, DSP memory.
 - If user is holding REBUILD button, enter menu to select startup delay mode.
 - If user was holding any other button, display "n0 SURE Funct ion" and then continue with startup.
- If production self test is enabled by configuration, do the test now
- Initialize the User Interface
- Enable RS-232
- Enter "RUNTIME" mode
- Start User Interface
- Check PUP variable and start processing audio if enabled

Startup Switches

The BD500 has operations which are used in the factory to prepare the unit to be shipped. Each operation is performed by turning on the unit while holding down a button until the $\epsilon 5\epsilon$ message goes away.

Turn off "Hide Fatal Error" option - WAIT AND EXIT key

This function sets the rER configuration variable to SHo . If a hardware problem were to cause a fatal error, and that condition occurred before the user interface was started, it would not be possible to get to the error log and read the error message if the reaction was set to $H'd$. This startup feature allows the reaction mode to be changed to SHo early in the startup process.

Restore Factory Defaults - CONFIGURE key

This function restores all factory defaults to the configuration

Perform Production Self-Test - BYPASS key

This function goes into a continuous loop self test. The self test cannot pass unless loopback connectors are installed on all audio and control connectors. This test may cause the configuration to be changed.

Select Delay Mode - REBUILD key

This function starts a menu that gives the user a choice of which delay mode the unit will be in. The choices are PFD (precision fixed delay) or BD (broadcast delay.) The chosen mode is saved and will be used in later operation until changed via this menu or via *configuration mode*. The menu presented offers bd or PFD as choices. Use the SNEEZE button to choose, and then the CONFIGURE button to lock in the selection. The unit will immediately enter BYPASS or go into the chosen delay mode, depending on the rUn configuration variable. (See *Configuration Mode in Chapter 3* and *Operation as a Precision Fixed Delay in Chapter 2*.)

Other Functions

The remaining front panel keys are unused at this time and, except for SNEEZE and DUMP keys, holding down an unused key during startup will result in an error message. SNEEZE and DUMP may be held down during startup with no consequences.

Error Processing

If an error occurs that the software is not able to deal with an error report is generated. This usually means that a mechanical or electrical failure has occurred with the unit or that a software design problem exists. The error reports are intended to help a factory technician diagnose the problem.

Error Log

After the report is generated the software saves the error report in an error log (configuration item $\epsilon o\epsilon$ - see Chapter 3.) The log has room for three unique error messages. If the log is full it is not added to. The log may be cleared from *configuration mode* (item $\epsilon \epsilon r$.) The first error message in the log is the first that occurred. Since the log stores only the first three unique messages there is no method for discovering how many errors occurred or at what rate.

Controlling the BD500's response to a fatal error

Next the BD500 looks at the configuration item (rER) to find if it should attempt to recover from the error ($H'd$) or stopping with the error on the display (SHo .) During an attempt to recover from the error the machine may restart. After restart the machine will attempt to return to the mode it was in when the problem occurred. If the configuration is set to stop with the error on the display the unit will flash $\epsilon r r$ and the error message.

Reading the Error Log

Whenever a fatal error occurs the machine runs a process that informs the user of the problem. The first operation performed will be to take the unit out of the audio path and into *bypass*. A configurable parameter selects whether the unit will stop and display a message, or will attempt to resolve the problem, rebooting if necessary.

Information Provided

This information is provided here for the sake of completeness and *not* with the intent that an end user might make parts replacement decisions.

Error Codes

- A04 The 1st memory test program was uploaded to the coprocessor successfully and then run. This error message indicates that the test program failed to make it to the first marker. This means that the coprocessor test program crashed. This does not indicate a memory failure although there may be a short between memory select lines and processor control lines.
- A05 The 1st memory test program was uploaded to the coprocessor successfully and then run. This error message indicates that the test program failed to make it to the second marker (end of write phase). This means that the coprocessor test program crashed. This does not indicate a memory failure although there may be a short between memory select lines and processor control lines.
- A06 The 1st memory test program was uploaded to the coprocessor successfully and then run. This error message indicates that the test program failed to make it to the second marker (end of read phase). This means that the coprocessor test program crashed. This does not indicate a memory failure although there may be a short between memory select lines and processor control lines.
- A07 During the first coprocessor memory test an error was found by the memory test but the reported error code does not match one in the motherboard CPU's program.
- A08 Error found by the 1st coprocessor external memory test. The error appears to be a static memory error found during the write cycle, i.e. a particular location didn't hold a data word for several instruction times. This could be a missing or badly soldered chip or a bad address or data line.
- A09 Error found by the 1st coprocessor external memory test. The error appears to be a dynamic memory error found during the write cycle, i.e. a particular location didn't hold a data word for several instruction times. A09 was using X basepage access. A10 was using P basepage access, A11 was using Y banked page access. X basepage access is first. If A09 occurs then the DRAM may be totally dead or poorly socketed.
- A10 Error found by the 1st coprocessor external memory test. The error appears to be a dynamic memory error found during the write cycle, i.e. a particular location didn't hold a data word for several instruction times. A09 was using X basepage access. A10 was using P basepage access, A11 was using Y banked page access. X basepage access is first. If A09 occurs then the DRAM may be totally dead or poorly socketed.
- A11 Error found by the 1st coprocessor external memory test. The error appears to be a dynamic memory error found during the write cycle, i.e. a particular location didn't hold a data word for several instruction times. A09 was using X basepage access. A10 was using P basepage access, A11 was using Y banked page access. X basepage access is first. If A09 occurs then the DRAM may be totally dead or poorly socketed.
- A12 Error found by the 1st coprocessor external memory test. The error appears to be a static memory error found during the read cycle, i.e. the memory was changed by some later address write or other failure.
- A13 Error found by the 1st coprocessor external memory test. The test reports that a memory failure was found during the first read back cycle. The error was detected when the dynamic RAM was accessed using the X select line.
- A14 Error found by the 1st coprocessor external memory test. The test reports that a memory failure was found during the first read back cycle. The error was detected when the dynamic RAM was accessed using the P select line.
- A15 Error found by the 1st coprocessor external memory test. The test reports that a memory failure was found during the first read back cycle. The error was detected when the dynamic RAM was accessed using the Y select line.
- A16 Error found by the 1st coprocessor external memory test. During the 2nd read back of coprocessor external static RAM an error was found.
- A17 Error found by the 1st coprocessor external memory test. The test reports that a memory failure occurred that is related to a failure in the refresh circuitry. The error was detected when the dynamic RAM was accessed using the X select line.
- A18 Error found by the 1st coprocessor external memory test. The test reports that a memory failure occurred that is related to a failure in the refresh circuitry. The error was detected when the dynamic RAM was accessed using the P select line.
- A19 Error found by the 1st coprocessor external memory test. The test reports that a memory failure occurred that is related to a failure in the refresh circuitry. The error was detected when the dynamic RAM was accessed using the Y select line.
- A21 During start-up (after the coprocessor is already known to be working) a failure was reported by the motherboard processor where it appears the coprocessor failed to receive a word of information from the motherboard. The motherboard processor eventually got tired of waiting. This is most likely caused by a software crash on the coprocessor. The crash may have been caused by intermittent hardware.
- A22 Similar to A21, this error indicates that the motherboard processor was waiting for the coprocessor to transmit a word of information to the motherboard when it gave up waiting and generated this error message.
- A30 During start-up a firmware error on the motherboard processor occurred. The specific error is that sethostwriteptr, part of the motherboard to coprocessor transmit driver suite, was called with bad parameters. This looks like a programming bug but might (unlikely) have been caused by a hardware problem on the motherboard.
- A32 During start-up the motherboard processor determined that we arrived at a programming instruction waiting for the coprocessor to finish processing a data word transmission previously issued by the motherboard. We shouldn't get here because the previous process that would have issued that hardware interrupt would not have exited without the dataword transmission being cleared. This means that the coprocessor trashed its own incoming data bits (TxRDY/TxEMPTY) without the motherboard CPU initiating it, or that the motherboard program has a bug and somehow got out of the transmit function without waiting for the data bits to be clear.

- A33 During start-up the motherboard processor determined that the coprocessor was in a bad state. The coprocessor has a pending hardware interrupt (CVR full) that should have been handled already. The driver indicating the error is sethostwriteptr, part of the system to transmit a word to the coprocessor. We shouldn't to this condition because the previous motherboard driver that would have issued that hardware interrupt would not have exited without the interrupt being cleared. This means that the coprocessor went back into the interrupt state (CVR full) without the motherboard CPU initiating it, or that the motherboard program has a bug. Note that the receive driver has been called and exited successfully many times since the last power-up.
- A34 This is the opposite of A33. This error occurs when waiting to leave sethostwriteptr, part of the coprocessor/motherboard processor transmit driver. This error, issued only during start-up, indicates that the coprocessor was sent a hardware interrupt to receive a data word and the coprocessor never accepted the hardware interrupt. This means that the coprocessor is locked up with interrupts disabled, or that there is a hardware function in the motherboard to coprocessor communications, or that the software on the motherboard processor is wrong. Note that the receive driver has been called and exited successfully many times since the last power-up.
- A35 This is the opposite of A32. This error occurs during start-up when waiting to leave sethostwriteptr, part of the motherboard to coprocessor communications suite. This error, issued only during start-up, indicates that the coprocessor was sent a data word and the coprocessor never read the word, clearing the TxRDY/TxEMPTY bits.. This means that the coprocessor receiver program is not functioning. Note that this driver has been called and exited successfully many times since the last power-up.
- A40 During start-up a firmware error on the motherboard processor occurred. The specific error is that sethostreadptr, part of the motherboard to coprocessor receive driver suite, was called with bad parameters. This looks like a programming bug but might (unlikely) have been caused by a hardware problem on the motherboard. Note that this driver has been called and exited successfully many times since the last power-up.
- A41 During start-up, the driver for motherboard to coprocessor receive communications determined that the coprocessor was hung up processing the previous message (TxRDY/TxEMPTY). This indicates that the coprocessor did something or that the motherboard program has a bug. Note that the receive driver has been called and exited successfully many times since the last power-up.
- A42 During start-up the motherboard processor determined that we arrived at a programming instruction waiting for the coprocessor to finish processing a hardware interrupt previously issued by the motherboard. The driver indicating the error is attempting to receive a word from the coprocessor during sethostreadptr, part of the coprocessor to motherboard communications driver. We shouldn't get to this condition because the previous driver that would have issued that hardware interrupt would not have exited without the interrupt being cleared. This means that the coprocessor went back into the interrupt state (CVR full) without the motherboard CPU initiating it, or that the motherboard program has a bug. Note that the receive driver has been called and exited successfully many times since the last power-up.
- A43 This is the opposite of A42. This error occurs when waiting to leave sethostreadptr, part of the coprocessor/motherboard receive drivers. This error, issued only during start-up, indicates that the coprocessor was sent a hardware interrupt to transmit a data word and the coprocessor never accepted the hardware interrupt. This means that the coprocessor is locked up with interrupts disabled, or that there is a hardware function in the motherboard to coprocessor communications, or that the software on the motherboard processor is wrong. Note that the receive driver has been called and exited successfully many times since the last power-up.
- A44 This is the opposite of A41. This error occurs during start-up when waiting to leave sethostreadptr, part of the coprocessor/motherboard receive drivers. This error, issued only during start-up, indicates that the coprocessor was sent an address word and the coprocessor never read the word, clearing the TxRDY/TxEMPTY bits.. This means that the coprocessor receiver program is not functioning. Note that the receive driver has been called and exited successfully many times since the last power-up.
- A45 This error occurs during start-up when waiting to leave sethostreadptr, part of the coprocessor/motherboard receive drivers. This error, issued only during start-up, indicates that the coprocessor was sent the address word and the coprocessor read the address word, but never sent the first data word. This means that the coprocessor receiver program is not functioning. Note that the receive driver has been called and exited successfully many times since the last power-up.
- A46 This error indicates a firmware error on the motherboard processor. The error was reported during start-up when a part of the motherboard processor driver to write to the coprocessor was called during a read sequence.
- A47 This error indicates a firmware error on the motherboard processor. The error was reported during start-up when a part of the motherboard processor driver to read from the coprocessor was called during a write sequence.
- A48 During start-up a test is made to see if the motherboard CPU data space was initialized by the motherboard boot code. This error indicates initialization did not take place. This is a firmware error.
- A50 The *factory burn-in* coprocessor external memory test program was uploaded to the coprocessor successfully and then run. This error message indicates that the test program failed to make it to the first marker. This means that the coprocessor test program crashed. This does not indicate a memory failure although there may be a short between memory select lines and processor control lines.
- A51 The *factory burn-in* coprocessor external memory test program was uploaded to the coprocessor successfully and then run. This error message indicates that the test program failed to make it to the second marker (end of write phase). This means that the coprocessor test program crashed. This does not indicate a memory failure although there may be a short between memory select lines and processor control lines.
- A52 The *factory burn-in* coprocessor external memory test program was uploaded to the coprocessor successfully and then run. This error message indicates that the test program failed to make it to the second marker (end of pre-refresh read back phase). This means that the coprocessor test program crashed. This does not indicate a memory failure although there may be a short between memory select lines and processor control lines.

- A53 The *factory burn-in* coprocessor external memory test program was uploaded to the coprocessor successfully and then run. This error message indicates that the test program failed to make it to the second marker (end of refresh test phase). This means that the coprocessor test program crashed. This does not indicate a memory failure although there may be a short between memory select lines and processor control lines.
- A54 The *factory burn-in* coprocessor external memory test program was uploaded to the coprocessor successfully and then run. This error message indicates that the test program failed to make it to the second marker (end of post-refresh read back phase). This means that the coprocessor test program crashed. This does not indicate a memory failure although there may be a short between memory select lines and processor control lines.
- A55 During the *factory burn-in* coprocessor external memory test program an error was found by the memory test but the reported error code does not match one in the motherboard CPU's program.
- A56 The *factory burn-in* coprocessor external memory test program was uploaded to the coprocessor successfully and then run. This error message indicates that the test program crashed after reporting an error condition. This does not indicate a memory failure although there may be a short between memory select lines and processor control lines.
- A57 The *factory burn-in* coprocessor external memory test program was uploaded to the coprocessor during start-up, in order to read its version number and to robustly test the communications link. Three validity tests are run on newly uploaded DSP boot code before it is used. The first two of those tests are to write words to internal memory and then read them back. The first read did not verify.
- A58 The *factory burn-in* coprocessor external memory test program was uploaded to the coprocessor during start-up, in order to read its version number and to robustly test the communications link. Three validity tests are run on newly uploaded DSP boot code before it is used. The first two of those tests are to write words to internal memory and then read them back. The second read did not verify.
- A60 The *factory burn-in* coprocessor external memory test program was uploaded to the coprocessor during start-up, in order to read its version number and to robustly test the communications link. Three validity tests are run on newly uploaded DSP boot code before it is used. The 3rd test is to read back the entire boot program and verify it against the copy on the motherboard ROMs. That test failed. The particular version of the external memory test program uploaded was for the 1MByte RAMs.
- A61 The *factory burn-in* coprocessor external memory test program was uploaded to the coprocessor during a burn-in test run. Three validity tests are run on newly uploaded DSP boot code before it is used. The 3rd test is to readback the entire boot program and verify it against the copy on the motherboard ROMs. That test failed. The particular version of the external memory test program uploaded was for the 4MByte RAMs.
- A62 The *factory burn-in* coprocessor external memory test program was uploaded to the coprocessor during a burn-in test run. Three validity tests are run on newly uploaded DSP boot code before it is used. The 3rd test is to readback the entire boot program and verify it against the copy on the motherboard ROMs. That test failed. The particular version of the external memory test program uploaded was for the 1MByte RAMs.
- A63 The *factory burn-in* coprocessor external memory test program was uploaded to the coprocessor during a burn-in test run. Three validity tests are run on newly uploaded DSP boot code before it is used. The first two of those tests are to write words to internal memory and then read them back. The first read did not verify.
- A64 The *factory burn-in* coprocessor external memory test program was uploaded to the coprocessor during a burn-in test run. Three validity tests are run on newly uploaded DSP boot code before it is used. The first two of those tests are to write words to internal memory and then read them back. The second read did not verify.
- A80 During startup the audio init function was unable to initialize the input hardware on a digital audio card.
- A81 During startup the audio init function was unable to initialize the output hardware on a digital audio card.
- A82 During startup the audio init function was unable to initialize the input or output hardware on a digital audio card.
- A84 During startup the audio board initialization couldn't identify the audio card. This could indicate there is a new audio card unknown to this software version, that the ID # is incorrect on the card, or it could be an interconnect problem between the motherboard and the audio card.
- A85 During startup the audio board initialization read a 0 for the audio card ID. This could indicate that the audio card is not installed, that the ID # is incorrect on the card, or that there is an interconnect problem between the motherboard and the audio card.
- A86 The DSP DRAM has been checked via the DSP startup memory test. It passed the 1st memory test. However, the 2nd test determined that the DRAM is small and not suitable to be used with the installed audio card. The original BD500 audio card could be supported with this size DSP. The installed audio card needs more RAM for support. This message is reported during startup.
- A87 The Broadcast Profanity Delay coprocessor software was loaded into the coprocessor but the sample processing part of the software does not appear to be running. The communications part of the software is running so the coprocessor is not crashed. It may be that the sample clock isn't running fast enough, or at all, or that there is a firmware problem. It might also be that there is an intermittent in the connects to the coprocessor card or the audio card.
- A88 During startup the coprocessor is initialized with the boot software, having passed several tests. In this part of the program the sample clock interrupt signal to the coprocessor is being tested. This error indicates that the sample clock is running slower than it should, given the current motherboard sample clock setting. Check the audio card, DSP card and sample clock generator.

- A89 During startup the coprocessor is initialized with the boot software, having passed several tests. In this part of the program the sample clock interrupt signal to the coprocessor is being tested. This error indicates that the sample clock is running faster than it should, given the current motherboard sample clock setting. Check the audio card, DSP card and sample clock generator.
- A90 During startup the coprocessor is initialized with the boot software, having passed several tests. In this part of the program the sample clock interrupt signal to the coprocessor is being tested. This error indicates that the sample clock is not running at all, even though the current motherboard sample clock setting has it that it should. Check the audio card, DSP card and sample clock generator.
- A91 This error message indicates that during startup the coprocessor has complained many times about getting an audio card interrupt many times while the coprocessor was busy processing an earlier audio card interrupt. Normally a redundant audio card interrupt could indicate that the sample rate glitched (not unlikely if using AES/EBU). This is not supposed to happen many times in a short period however.
- A94 During startup the UI sent a bad command to the coprocessor drivers. This would indicate a firmware error.
- A95 During startup the auxiliary port driver (delayed control lines) reported that the delay amount is longer than allowed. This would indicate a firmware error.
- D00->D11 During DSP_START1 (coprocessor startup) the coprocessor malfunctioned. Since this happened the very first time the coprocessor was addressed we can guess that it did not start running the boot code. This failure indicates a problem with the coprocessor->motherboard processor host port or with the coprocessor CPU itself. The coprocessor external memory is not involved in this failure.
- D00 During DSP_START1 (coprocessor startup) a failure was reported by the motherboard processor where it appears the coprocessor failed to receive a word of information from the motherboard. The motherboard processor eventually got tired of waiting. This failure indicates a problem with the coprocessor->motherboard processor host port or with the coprocessor CPU itself. The coprocessor external memory is not involved in this failure.
- D01 During DSP_START1 (coprocessor startup) a failure was reported by the motherboard processor where it appears the motherboard processor was waiting for the coprocessor to transmit a word of information to the motherboard when it gave up waiting and generated this error message. This failure indicates a problem with the coprocessor->motherboard processor host port or with the coprocessor CPU itself. The coprocessor external memory is not involved in this failure.
- D02 During DSP_START1 the motherboard processor determined that we arrived at a programming instruction waiting for the coprocessor to finish processing a data word transmission previously issued by the motherboard. We shouldn't get here because the previous process that would have issued that hardware interrupt would not have exited without the dataword transmission being cleared. This means that the coprocessor trashed it's own incoming data bits (TxRDY/TxEMPTY) without the motherboard CPU initiating it, or that the motherboard program has a bug and somehow got out of the transmit function without waiting for the data bits to be clear.
- D03 During DSP_START1 the motherboard processor determined that the coprocessor was in a bad state. The coprocessor has a pending hardware interrupt (CVR full) that should have been handled already. The driver indicating the error is sethostwriteptr, part of the system to transmit a word to the coprocessor. We shouldn't to this condition because the previous motherboard driver that would have issued that hardware interrupt would not have exited without the interrupt being cleared. This failure indicates a problem with the coprocessor->motherboard processor host port or with the coprocessor CPU itself. The coprocessor external memory is not involved in this failure.
- D04 This is the opposite of D03. This error occurs when waiting to leave sethostwriteptr, part of the coprocessor/motherboard processor transmit driver. This error, issued only during DSP_START1, indicates that the coprocessor was sent a hardware interrupt to receive a data word and the coprocessor never accepted the hardware interrupt. This failure indicates a problem with the coprocessor->motherboard processor host port or with the coprocessor CPU itself. The coprocessor external memory is not involved in this failure.
- D05 This is the opposite of D02. This error occurs during startup when waiting to leave sethostwriteptr, part of the motherboard to coprocessor communications suite. This error, issued only during DSP_START1, indicates that the coprocessor was sent a data word and the coprocessor never read the word, clearing the TxRDY/TxEMPTY bits.. This failure indicates a problem with the coprocessor->motherboard processor host port or with the coprocessor CPU itself. The coprocessor external memory is not involved in this failure.
- D07 During DSP_START1, the driver for motherboard to coprocessor receive communications determined that the coprocessor was hung up processing the previous message (TxRDY/TxEMPTY). This failure indicates a problem with the coprocessor->motherboard processor host port or with the coprocessor CPU itself. The coprocessor external memory is not involved in this failure.
- D08 During DSP_START1 the motherboard processor determined that we arrived at a programming instruction waiting for the coprocessor to finish processing a hardware interrupt previously issued by the motherboard. The driver indicating the error is attempting to receive a word from the coprocessor during sethosreadptr, part of the coprocessor to motherboard communications driver. We shouldn't get to this condition because the previous driver that would have issued that hardware interrupt would not have exited without the interrupt being cleared. This means that the coprocessor went back into the interrupt state (CVR full) without the motherboard CPU initiating it, or that the motherboard program has a bug. This failure indicates a problem with the coprocessor->motherboard processor host port or with the coprocessor CPU itself. The coprocessor external memory is not involved in this failure.

- D09 This is the opposite of D08. This error occurs when waiting to leave sethostreadptr, part of the coprocessor/motherboard receive drivers. This error, issued only during DSP_START1, indicates that the coprocessor was sent a hardware interrupt to transmit a data word and the coprocessor never accepted the hardware interrupt. This means that the coprocessor is locked up with interrupts disabled, or that there is a hardware function in the motherboard to coprocessor communications, or that the software on the motherboard processor is wrong. Note that the receive driver has been called and exited successfully many times since the last power-up.
- D10 This is the opposite of D07. This error occurs during startup when waiting to leave sethostreadptr, part of the coprocessor/motherboard receive drivers. This error, issued only during DSP_START1, indicates that the coprocessor was sent an address word and the coprocessor never read the word, clearing the TxRDY/TxEMPTY bits.. This means that the coprocessor receiver program is not functioning. Note that the receive driver has been called and exited successfully many times since the last power-up.
- D11 This error occurs during DSP_START1 when waiting to leave sethostreadptr, part of the coprocessor/motherboard receive drivers. This error, issued only during startup, indicates that the coprocessor was sent the address word and the coprocessor read the address word, but never sent the first data word. This means that the coprocessor receiver program is not functioning. Note that the receive driver has been called and exited successfully many times since the last power-up.
- D12 This error indicates a firmware error on the motherboard processor. The error was reported during DSP_START1 (coprocessor startup) when a part of the motherboard processor driver to write to the coprocessor was called during a read sequence.
- D13 During DSP_START1 (coprocessor startup) a read was requested from the coprocessor before the read address was set up. This indicates a motherboard firmware bug.
- D14 During DSP_START2 (after the coprocessor is already known to be working) a failure was reported by the motherboard processor where it appears the coprocessor failed to receive a word of information from the motherboard. The motherboard processor eventually got tired of waiting. This is most likely caused by a software crash on the coprocessor. The crash may have been caused by intermittent hardware. Since this happened after the first time the coprocessor was successfully accessed we can guess that either a bug exists in the DSP boot code or there is an intermittent problem in the coprocessor<->motherboard processor host port or with the coprocessor CPU itself. The coprocessor external memory is not involved in this failure.
- D15 Similar to D14, this error indicates that the motherboard processor was waiting for the coprocessor to transmit a word of information to the motherboard when it gave up waiting and generated this error message.
- D17 During DSP_START2 the motherboard processor determined that we arrived at a programming instruction waiting for the coprocessor to finish processing a data word transmission previously issued by the motherboard. We shouldn't get here because the previous process that would have issued that hardware interrupt would not have exited without the dataword transmission being cleared. This means that the coprocessor trashed it's own incoming data bits (TxRDY/TxEMPTY) without the motherboard CPU initiating it, or that the motherboard program has a bug and somehow got out of the transmit function without waiting for the data bits to be clear. Since this happened after the first time the coprocessor was successfully accessed we can guess that either a bug exists in the DSP boot code or there is an intermittent problem in the coprocessor<->motherboard processor host port or with the coprocessor CPU itself. The coprocessor external memory is not involved in this failure.
- D18 During DSP_START2 the motherboard processor determined that the coprocessor was in a bad state. The coprocessor has a pending hardware interrupt (CVR full) that should have been handled already. The driver indicating the error is sethostwriteptr, part of the system to transmit a word to the coprocessor. We shouldn't to this condition because the previous motherboard driver that would have issued that hardware interrupt would not have exited without the interrupt being cleared. This means that the coprocessor went back into the interrupt state (CVR full) without the motherboard CPU initiating it, or that the motherboard program has a bug. Since this happened after the first time the coprocessor was successfully accessed we can guess that either a bug exists in the DSP boot code or there is an intermittent problem in the coprocessor<->motherboard processor host port or with the coprocessor CPU itself. The coprocessor external memory is not involved in this failure.
- D19 This is the opposite of D18. This error occurs when waiting to leave sethostwriteptr, part of the coprocessor/motherboard processor transmit driver. This error, issued only during DSP_START2, indicates that the coprocessor was sent a hardware interrupt to receive a data word and the coprocessor never accepted the hardware interrupt. This means that the coprocessor is locked up with interrupts disabled, or that there is a hardware function in the motherboard to coprocessor communications, or that the software on the motherboard processor is wrong. Since this happened after the first time the coprocessor was successfully accessed we can guess that either a bug exists in the DSP boot code or there is an intermittent problem in the coprocessor<->motherboard processor host port or with the coprocessor CPU itself. The coprocessor external memory is not involved in this failure.
- D20 This is the opposite of D17. This error occurs during startup when waiting to leave sethostwriteptr, part of the motherboard to coprocessor communications suite. This error, issued only during DSP_START2, indicates that the coprocessor was sent a data word and the coprocessor never read the word, clearing the TxRDY/TxEMPTY bits.. This means that the coprocessor receiver program is not functioning. Since this happened after the first time the coprocessor was successfully accessed we can guess that either a bug exists in the DSP boot code or there is an intermittent problem in the coprocessor<->motherboard processor host port or with the coprocessor CPU itself. The coprocessor external memory is not involved in this failure.

- D22 During DSP_START2, the driver for motherboard to coprocessor receive communications determined that the coprocessor was hung up processing the previous message (TxRDY/TxEMPTY). This indicates that the coprocessor did something or that the motherboard program has a bug. Since this happened after the first time the coprocessor was successfully accessed we can guess that either a bug exists in the DSP boot code or there is an intermittent problem in the coprocessor->motherboard processor host port or with the coprocessor CPU itself. The coprocessor external memory is not involved in this failure.
- D23 During DSP_START2 the motherboard processor determined that we arrived at a programming instruction waiting for the coprocessor to finish processing a hardware interrupt previously issued by the motherboard. The driver indicating the error is attempting to receive a word from the coprocessor during sethostreadptr, part of the coprocessor to motherboard communications driver. We shouldn't get to this condition because the previous driver that would have issued that hardware interrupt would not have exited without the interrupt being cleared. This means that the coprocessor went back into the interrupt state (CVR full) without the motherboard CPU initiating it, or that the motherboard program has a bug. Since this happened after the first time the coprocessor was successfully accessed we can guess that either a bug exists in the DSP boot code or there is an intermittent problem in the coprocessor->motherboard processor host port or with the coprocessor CPU itself. The coprocessor external memory is not involved in this failure.
- D24 This is the opposite of D23. This error occurs when waiting to leave sethostreadptr, part of the coprocessor/motherboard receive drivers. This error, issued only during DSP_START2, indicates that the coprocessor was sent a hardware interrupt to transmit a data word and the coprocessor never accepted the hardware interrupt. This means that the coprocessor is locked up with interrupts disabled, or that there is a hardware function in the motherboard to coprocessor communications, or that the software on the motherboard processor is wrong. Since this happened after the first time the coprocessor was successfully accessed we can guess that either a bug exists in the DSP boot code or there is an intermittent problem in the coprocessor->motherboard processor host port or with the coprocessor CPU itself. The coprocessor external memory is not involved in this failure.
- D25 This is the opposite of D22. This error occurs during DSP_START2 when waiting to leave sethostreadptr, part of the coprocessor/motherboard receive drivers. This error, issued only during startup, indicates that the coprocessor was sent an address word and the coprocessor never read the word, clearing the TxRDY/TxEMPTY bits.. This means that the coprocessor receiver program is not functioning. Since this happened after the first time the coprocessor was successfully accessed we can guess that either a bug exists in the DSP boot code or there is an intermittent problem in the coprocessor->motherboard processor host port or with the coprocessor CPU itself. The coprocessor external memory is not involved in this failure.
- D26 This error occurs during DSP_START2 when waiting to leave sethostreadptr, part of the coprocessor/motherboard receive drivers. This error, issued only during DSP_START2, indicates that the coprocessor was sent the address word and the coprocessor read the address word, but never sent the first data word. This means that the coprocessor receiver program is not functioning. Since this happened after the first time the coprocessor was successfully accessed we can guess that either a bug exists in the DSP boot code or there is an intermittent problem in the coprocessor->motherboard processor host port or with the coprocessor CPU itself. The coprocessor external memory is not involved in this failure.
- D27 This error indicates a firmware error on the motherboard processor. The error was reported during DSP_START2 (coprocessor startup) when a part of the motherboard processor driver to write to the coprocessor was called during a read sequence.
- D28 This error indicates a firmware error on the motherboard processor. The error was reported during DSP_START2 when a part of the motherboard processor driver to read from the coprocessor was called during a write sequence.
- D30 During DSP_START2 a test program is uploaded from the motherboard processor. This error message indicates that communications with the coprocessor is working ok but that the readback of the first test word from the internal memory on the coprocessor chip failed. The external coprocessor memory is not involved.
- D31 This is the same as D30 except that the first readback worked and the second failed. The external coprocessor memory is not involved.
- D32 This is the same as D30 except that after the 1st and 2nd readbacks worked, we read back the entire boot program and got a verification error. Note that the main processor <-> coprocessor communications functions on both sides of the link are working apparently, but that the verification failed anyway. Also note that the program that failed to verify was uploaded into the coprocessor's internal memory. The external coprocessor memory is not involved.
- D33 After the first program was uploaded and verified, the 1st memory test program is uploaded. This error is the same as D30 except that it is after the communications has been rigorously tested.
- D34 This is the same as D33 except that the first readback worked and the second failed. The external coprocessor memory is not involved.
- D35 This error message means that the 1st memory test program was not uploaded successfully. The program was read back and showed to have errors during upload. This is not supposed to happen.
- D36 This is the same as D33 except that we were doing the 1st readback from the 2nd memory test program.
- D37 This is the same as D36 except that we were doing the 2nd readback.
- D38 This error message means that the 2nd memory test program was not uploaded successfully. The program was read back and showed to have errors during upload. This is not supposed to happen.

- D39 After the initial coprocessor boot and after the test suites, the final operating system is uploaded to the coprocessor. This error message indicates that the communications is working but that readback of an internal memory location failed.
- D40 This is the same as D38 except that the first readback worked and the second failed.
- E01 At startup the coprocessor was looked for by inspecting the registers in the coprocessor that indicate communications status. All status bits were set to 1, indicating that the communications lines were floating. The motherboard processor has decided that there is no coprocessor card installed. This is a fatal error.
- E02 At startup the five volt power supply level is checked. This indicates that the voltage was out of range.
- E03 Errors occurred during communications between the main processor and the front panel coprocessor. This message indicates the number of errors per minute exceeded acceptable limits during run-time.
- E04 Errors occurred during communications between the main processor and the front panel coprocessor. This message indicates the number of errors per minute exceeded acceptable limits during startup related operations..
- E05 The front panel communications stopped working for a long period of time. This error indicates that this happened during run-time. The UI has been instructed to abort to BYPASS.
- E06 The front panel communications stopped working for a long period of time. This error indicates that this happened before run-time started.
- E18 This indicates that the coprocessor is running and answering but the audio processing loop isn't running. If this happens immediately after going from BYPASS to inline this means that the audio sample clock isn't getting to the coprocessor. This may be caused by a broken or missing audio card.
- E19 This error message indicates that during run-time the coprocessor has complained many times about getting an audio card interrupt many times while the coprocessor was busy processing an earlier audio card interrupt. Normally a redundant audio card interrupt could indicate that the sample rate glitched (not unlikely if using AES/EBU). This is not supposed to happen many times in a short period however.
- E21 During run-time (after the coprocessor is already known to be working) a failure was reported by the motherboard processor where it appears the coprocessor failed to receive a word of information from the motherboard. The motherboard processor eventually got tired of waiting. This is most likely caused by a software crash on the coprocessor. The crash may have been caused by intermittent hardware.
- E22 Similar to E21, this error indicates that during run-time the motherboard processor was waiting for the coprocessor to transmit a word of information to the motherboard when it gave up waiting and generated this error message.
- E30 During run time a firmware error on the motherboard processor occurred. The specific error is that sethostwriteptr, part of the motherboard to coprocessor transmit driver suite, was called with bad parameters. This looks like a programming bug but might (unlikely) have been caused by a hardware problem on the motherboard.
- E32 During run time the motherboard processor determined that we arrived at a programming instruction waiting for the coprocessor to finish processing a data word transmission previously issued by the motherboard. We shouldn't get here because the previous process that would have issued that hardware interrupt would not have exited without the dataword transmission being cleared. This means that the coprocessor trashed it's own incoming data bits (TxRDY/TxEMPTY) without the motherboard CPU initiating it, or that the motherboard program has a bug and somehow got out of the transmit function without waiting for the data bits to be clear.
- E33 During run time the motherboard processor determined that the coprocessor was in a bad state. The coprocessor has a pending hardware interrupt (CVR full) that should have been handled already. The driver indicating the error is sethostwriteptr, part of the system to transmit a word to the coprocessor. We shouldn't to this condition because the previous motherboard driver that would have issued that hardware interrupt would not have exited without the interrupt being cleared. This means that the coprocessor went back into the interrupt state (CVR full) without the motherboard CPU initiating it, or that the motherboard program has a bug. Note that the receive driver has been called and exited successfully many times since the last power-up.
- E34 This is the opposite of E33. This error occurs when waiting to leave sethostwriteptr, part of the coprocessor/motherboard processor transmit driver. This error, issued only during run time, indicates that the coprocessor was sent a hardware interrupt to receive a data word and the coprocessor never accepted the hardware interrupt. This means that the coprocessor is locked up with interrupts disabled, or that there is a hardware function in the motherboard to coprocessor communications, or that the software on the motherboard processor is wrong. Note that the receive driver has been called and exited successfully many times since the last power-up.
- E35 This is the opposite of E32. This error occurs during run time when waiting to leave sethostwriteptr, part of the motherboard to coprocessor communications suite. This error, issued only during run time, indicates that the coprocessor was sent a data word and the coprocessor never read the word, clearing the TxRDY/TxEMPTY bits.. This means that the coprocessor receiver program is not functioning. Note that this driver has been called and exited successfully many times since the last power-up.
- E40 During run time a firmware error on the motherboard processor occurred. The specific error is that sethostreadptr, part of the motherboard to coprocessor receive driver suite, was called with bad parameters. This looks like a programming bug but might (unlikely) have been caused by a hardware problem on the motherboard. Note that this driver has been called and exited successfully many times since the last power-up.
- E41 During run time, the driver for motherboard to coprocessor receive communications determined that the coprocessor was hung up processing the previous message (TxRDY/TxEMPTY). This indicates that the coprocessor did something or that the motherboard program has a bug. Note that the receive driver has been called and exited successfully many times since the last power-up.

- E42 During run time the motherboard processor determined that we arrived at a programming instruction waiting for the coprocessor to finish processing a hardware interrupt previously issued by the motherboard. The driver indicating the error is attempting to receive a word from the coprocessor during sethostreadptr, part of the coprocessor to motherboard communications driver. We shouldn't get to this condition because the previous driver that would have issued that hardware interrupt would not have exited without the interrupt being cleared. This means that the coprocessor went back into the interrupt state (CVR full) without the motherboard CPU initiating it, or that the motherboard program has a bug. Note that the receive driver has been called and exited successfully many times since the last power-up.
- E43 This is the opposite of E42. This error occurs when waiting to leave sethostreadptr, part of the coprocessor/motherboard receive drivers. This error, issued only during run time, indicates that the coprocessor was sent a hardware interrupt to transmit a data word and the coprocessor never accepted the hardware interrupt. This means that the coprocessor is locked up with interrupts disabled, or that there is a hardware function in the motherboard to coprocessor communications, or that the software on the motherboard processor is wrong. Note that the receive driver has been called and exited successfully many times since the last power-up.
- E44 This is the opposite of E41. This error occurs during run time when waiting to leave sethostreadptr, part of the coprocessor/motherboard receive drivers. This error, issued only during run time, indicates that the coprocessor was sent an address word and the coprocessor never read the word, clearing the TxRDY/TxEMPTY bits.. This means that the coprocessor receiver program is not functioning. Note that the receive driver has been called and exited successfully many times since the last power-up.
- E45 This error occurs during run time when waiting to leave sethostreadptr, part of the coprocessor/motherboard receive drivers. This error, issued only during run time, indicates that the coprocessor was sent the address word and the coprocessor read the address word, but never sent the first data word. This means that the coprocessor receiver program is not functioning. Note that the receive driver has been called and exited successfully many times since the last power-up.
- E46 This error indicates a firmware error on the motherboard processor. The error was reported during run time when a part of the motherboard processor driver to write to the coprocessor was called during a read sequence.
- E47 This error indicates a firmware error on the motherboard processor. The error was reported during run time when a part of the motherboard processor driver to read from the coprocessor was called during a write sequence.
- E90 During run time the UI sent a bad command to the coprocessor drivers. This would indicate a firmware error.
- E91 The configuration storage drivers reported a firmware error where a call was made to the driver with an invalid register number.
- E92 The User Interface program reports a firmware error where a change state was issued with the same state number as the previous state.
- E93 During start-up the configuration storage drivers reported a firmware error. Too many configuration storage elements are defined. This normally happens during software development when changes to the storage requirements are made.
- E94 During run-time the auxiliary port driver (delayed control lines) reported that the delay amount is longer than allowed. This would indicate a firmware error.
- E95 The configuration storage drivers indicate a failure in firmware where the initialization pointers in the configuration table are not correct.
- EA1 During DSP_START1 a firmware error on the motherboard processor occurred. The specific error is that sethostwriteptr, part of the motherboard to coprocessor transmit driver suite, was called with bad parameters. This looks like a programming bug but might (unlikely) have been caused by a hardware problem on the motherboard.
- EA2 During DSP_START1 a firmware error on the motherboard processor occurred. The specific error is that sethostreadptr, part of the motherboard to coprocessor receive driver suite, was called with bad parameters. This looks like a programming bug but might (unlikely) have been caused by a hardware problem on the motherboard.
- EA3 This error message indicates two problems. The first is that a firmware or hardware error occurred. The second is that we don't know what the error message was. This itself is a firmware error. The error was reported during DSP_START1.
- EA4 During DSP_START2 a firmware error on the motherboard processor occurred. The specific error is that sethostwriteptr, part of the motherboard to coprocessor transmit driver suite, was called with bad parameters. This looks like a programming bug but might (unlikely) have been caused by a hardware problem on the motherboard.
- EA5 During DSP_START2 a firmware error on the motherboard processor occurred. The specific error is that sethostreadptr, part of the motherboard to coprocessor receive driver suite, was called with bad parameters. This looks like a programming bug but might (unlikely) have been caused by a hardware problem on the motherboard.
- EA6 This error message indicates two problems. The first is that a firmware or hardware error occurred. The second is that we don't know what the error message was. This itself is a firmware error. The error was reported during DSP_START2.
- F01 During burn-in test operation the audio board initialization couldn't identify the audio card. This could indicate there is a new audio card unknown to this software version, that the ID # is incorrect on the card, or it could be an interconnect problem between the motherboard and the audio card.
- F03 During burn-in test operation the auxiliary port driver (delayed control lines) reported that the delay amount is longer than allowed. This would indicate a firmware error.
- F05 During burn in test operation the UI sent a bad command to the coprocessor drivers. This would indicate a firmware error.

- F07 After the initial coprocessor boot and after the test suites, the final operating system is uploaded to the coprocessor. This error message indicates that the communications is working but that read back of an internal memory location failed. This message was generated during burn-in test operation.
- F08 After the initial coprocessor boot and after the test suites, the final operating system is uploaded to the coprocessor. This error message indicates that the communications is working but that read back of an internal memory location failed. This message is similar to F07 except that the 1st word read back was correct and the 2nd was wrong. This message was generated during burn-in test operation.
- F09 During burn-in test operation the audio init function was unable to initialize the input or output hardware on a digital audio card.
- F10 During burn-in test operation the audio init function was unable to initialize the input hardware on a digital audio card.
- F11 During burn-in test operation the audio init function was unable to initialize the output hardware on a digital audio card.
- F12 The DSP DRAM has been checked via the DSP start-up memory test. It passed the 1st memory test. However, the 2nd test determined that the DRAM is small and not suitable to be used with the installed audio card. The original BD500 audio card could be supported with this size DSP. The installed audio card needs more RAM for support. This message is reported during burn-in test operation.
- F13 This error message indicates that during burn-in test operation the coprocessor has complained many times about getting an audio card interrupt many times while the coprocessor was busy processing an earlier audio card interrupt. Normally a redundant audio card interrupt could indicate that the sample rate glitched (not unlikely if using AES/EBU). This is not supposed to happen many times in a short period however.
- F14 During burn-in test operation the coprocessor is initialized with the boot software, having passed several tests. In this part of the program the sample clock interrupt signal to the coprocessor is being tested. This error indicates that the sample clock is not running at all, even though the current motherboard sample clock setting has it that it should. Check the audio card, DSP card and sample clock generator.
- F16 During burn-in test operation the coprocessor is initialized with the boot software, having passed several tests. In this part of the program the sample clock interrupt signal to the coprocessor is being tested. This error indicates that the sample clock is running slower than it should, given the current motherboard sample clock setting. Check the audio card, DSP card and sample clock generator.
- F17 During burn-in test operation the coprocessor is initialized with the boot software, having passed several tests. In this part of the program the sample clock interrupt signal to the coprocessor is being tested. This error indicates that the sample clock is running faster than it should, given the current motherboard sample clock setting. Check the audio card, DSP card and sample clock generator.
- F28 During burn-in test operation the audio board initialization read a 0 for the audio card ID. This could indicate that the audio card is not installed, that the ID # is incorrect on the card, or that there is an interconnect problem between the motherboard and the audio card.
- F45 During burn-in test operation (after the coprocessor is already known to be working) a failure was reported by the motherboard processor where it appears the coprocessor failed to receive a word of information from the motherboard. The motherboard processor eventually got tired of waiting. This is most likely caused by a software crash on the coprocessor. The crash may have been caused by intermittent hardware.
- F46 This error indicates that during burn-in test operation the motherboard processor was waiting for the coprocessor to transmit a word of information to the motherboard when it gave up waiting and generated this error message.
- F47 During burn-in test operation a firmware error on the motherboard processor occurred. The specific error is that sethostreadptr, part of the motherboard to coprocessor receive driver suite, was called with bad parameters. This looks like a programming bug but might (unlikely) have been caused by a hardware problem on the motherboard. Note that this driver has been called and exited successfully many times since the last power-up.
- F48 During burn-in test operation the driver for motherboard to coprocessor receive communications determined that the coprocessor was hung up processing the previous message (TxRDY/TxEMPTY). This indicates that the coprocessor did something or that the motherboard program has a bug. Note that the receive driver has been called and exited successfully many times since the last power-up.
- F49 During burn-in test operation the motherboard processor determined that we arrived at a programming instruction waiting for the coprocessor to finish processing a hardware interrupt previously issued by the motherboard. The driver indicating the error is attempting to receive a word from the coprocessor during sethostreadptr, part of the coprocessor to motherboard communications driver. We shouldn't get to this condition because the previous driver that would have issued that hardware interrupt would not have exited without the interrupt being cleared. This means that the coprocessor went back into the interrupt state (CVR full) without the motherboard CPU initiating it, or that the motherboard program has a bug. Note that the receive driver has been called and exited successfully many times since the last power-up.
- F50 This is the opposite of F49. This error occurs when waiting to leave sethostreadptr, part of the coprocessor/motherboard receive drivers. This error, issued only during burn-in test operation, indicates that the coprocessor was sent a hardware interrupt to transmit a data word and the coprocessor never accepted the hardware interrupt. This means that the coprocessor is locked up with interrupts disabled, or that there is a hardware function in the motherboard to coprocessor communications, or that the software on the motherboard processor is wrong. Note that the receive driver has been called and exited successfully many times since the last power-up.

- F51 This is the opposite of F48. This error occurs during burn-in test operation when waiting to leave sethostreadptr, part of the coprocessor/motherboard receive drivers. This error, issued only during burn-in test operation, indicates that the coprocessor was sent an address word and the coprocessor never read the word, clearing the TxRDY/TxEMPTY bits.. This means that the coprocessor receiver program is not functioning. Note that the receive driver has been called and exited successfully many times since the last power-up.
- F52 This error occurs during run time when waiting to leave sethostreadptr, part of the coprocessor/motherboard receive drivers. This error, issued only during burn-in test operation, indicates that the coprocessor was sent the address word and the coprocessor read the address word, but never sent the first data word. This means that the coprocessor receiver program is not functioning. Note that the receive driver has been called and exited successfully many times since the last power-up.
- F53 During burn-in test operation a firmware error on the motherboard processor occurred. The specific error is that sethostwriteptr, part of the motherboard to coprocessor transmit driver suite, was called with bad parameters. This looks like a programming bug but might (unlikely) have been caused by a hardware problem on the motherboard.
- F54 During burn-in test operation the motherboard processor determined that we arrived at a programming instruction waiting for the coprocessor to finish processing a data word transmission previously issued by the motherboard. We shouldn't get here because the previous process that would have issued that hardware interrupt would not have exited without the dataword transmission being cleared. This means that the coprocessor trashed it's own incoming data bits (TxRDY/TxEMPTY) without the motherboard CPU initiating it, or that the motherboard program has a bug and somehow got out of the transmit function without waiting for the data bits to be clear.
- F55 During burn-in test operation the motherboard processor determined that the coprocessor was in a bad state. The coprocessor has a pending hardware interrupt (CVR full) that should have been handled already. The driver indicating the error is sethostwriteptr, part of the system to transmit a word to the coprocessor. We shouldn't to this condition because the previous motherboard driver that would have issued that hardware interrupt would not have exited without the interrupt being cleared. This means that the coprocessor went back into the interrupt state (CVR full) without the motherboard CPU initiating it, or that the motherboard program has a bug. Note that the receive driver has been called and exited successfully many times since the last power-up.
- F56 This is the opposite of F55. This error occurs when waiting to leave sethostwriteptr, part of the coprocessor/motherboard processor transmit driver. This error, issued only during burn-in test operation, indicates that the coprocessor was sent a hardware interrupt to receive a data word and the coprocessor never accepted the hardware interrupt. This means that the coprocessor is locked up with interrupts disabled, or that there is a hardware function in the motherboard to coprocessor communications, or that the software on the motherboard processor is wrong. Note that the receive driver has been called and exited successfully many times since the last power-up.
- F57 This is the opposite of F54. This error occurs during run time when waiting to leave sethostwriteptr, part of the motherboard to coprocessor communications suite. This error, issued only during burn-in test operation, indicates that the coprocessor was sent a data word and the coprocessor never read the word, clearing the TxRDY/TxEMPTY bits.. This means that the coprocessor receiver program is not functioning. Note that this driver has been called and exited successfully many times since the last power-up.
- F60 This error indicates a firmware error on the motherboard processor. The error was reported during burn-in test operation when a part of the motherboard processor driver to write to the coprocessor was called during a read sequence.
- F45 This error indicates a firmware error on the motherboard processor. The error was reported during burn-in test operation when a part of the motherboard processor driver to read from the coprocessor was called during a write sequence.
- F61 During burn-in test operation (after the coprocessor is already known to be working) a failure was reported by the motherboard processor where it appears the coprocessor failed to receive a word of information from the motherboard. The motherboard processor eventually got tired of waiting. This is most likely caused by a software crash on the coprocessor. The crash may have been caused by intermittent hardware.
- F65 During burn-in test operation the audio card initialization could not identify the audio card.
- F68 This error indicates a firmware error on the motherboard processor. The error was reported during burn-in test operation when a part of the motherboard processor driver to write to the coprocessor was called during a read sequence.
- F99 During burn-in test operation a failure occurred. The error reporting system was triggered by that failure. This error indicates that the error reporting system was called by the motherboard firmware with an unlisted set of circumstances.
- 999 This error message indicates that an unlisted combination of error condition and run modes were passed to the error reporting system. A firmware or hardware error occurred that triggered this but a further error must exist in order to reach this message.

Appendix G Specifications

Physical:

Size inches	1.75h x 19w x 12.5d
Size centimeters	4.4h x 48.3w x 32d
Weight	6 lbs. net
Shipping weight	10 lbs.
Power	50 watts, 100-240V AC 50/60Hz
Fuse	1-Amp Slow Blow

Basic Audio - Analog Only

Analog inputs/outputs:

Connector	XLR, pin 2 hot, true differential balanced +4dBm nominal, +20dBm max.
Sample Rate	32kHz, 18bit/sample (note: processing limits audio to 16 bit/sample)
Frequency Response	5Hz to 15kHz, + < 1dB
Signal to Noise ratio	>90dB, 'A' weighted.
Distortion	.05%, (.03% typical) @ 1kHz, 1dB below clipping in stable delay state.
Total Harmonic Distortion + Noise	85dB with input levels (INP) at 10dB, output (OUT) at 0dB.

Optional Audio - Digital and Analog

AES/EBU Digital inputs/outputs:

Connector	XLR
Sample Rate	32-49kHz, 24 bit/sample (note: processing limits audio to 16bit/sample)

Analog inputs/outputs with digital audio option:

Connector	XLR, pin 2 hot, true differential balanced +4dBm nominal, +20dBm max.
Sample Rate	48kHz, 20 bit/sample (note: processing limits audio to 16 bit/sample)
Frequency Response	5Hz to 22kHz, + < 1dB
Signal to Noise ratio	>90dB, 'A' weighted
Distortion	.005%, (.003% typical) @ 1kHz, 1dB below clipping in stable delay state
Total Harmonic Distortion + Noise	87.5dB under input levels (INP) at 10dB, all others at 0dB

Basic Rear Panel Control Signals:

Remote Field Contact Supply Voltage (pin 9)

Voltage	nominal 5v
Current	100mA max

Control Signals

Remote outputs	relay contacts - 30V, 1A maximum
Remote inputs	relay coils, 180ohm, 3.75V to 7.5V

Optional Rear Panel Control Signals:

Remote Field Contact Supply Voltage (pin 1)

Voltage	min of 10v, max of 15v, nominal 11.3v
Current	100mA max

External Power Supply Bias Input

Voltage	maximum of 25v
---------	----------------

Control Signals

Remote outputs	sink a maximum of 500mA individually, or 200mA each with all outputs driven
Remote inputs	1mA at 4.5v minimum, 25v max

*These specifications are subject
to change without notice.*

Appendix H Warranty Information

Limited Warranty

and other legal stuff, terms and conditions

The BD500 is built to exacting quality standards, and should give years of trouble-free service.

If you are experiencing problems which are not cleared up (or explained as normal) in this manual, your recourse is this warranty.

What the warranty does and does not cover

The BD500 has a one year warranty against defects in material and workmanship. During this period we will repair or replace (at our option) the unit.

This means that if the unit fails under normal operation, because of parts that become defective, or because of defects in construction that later become apparent (such as bad solder joints, printed circuit board traces, etc.), we will repair the unit at no charge for parts and labor. We also assume a limited responsibility for shipping charges, as detailed below.

The warranty *does not cover* damage or defects due to accident or abuse. The BD500 is a complex piece of equipment that does not react well to being dropped, bounced, crushed, soaked or exposed to excessively high voltages. If the unit becomes defective for these or similar causes, and the unit is deemed to be economically repairable, we will repair it and charge our normal rates.

It *does not cover* shipping damage, either to or from Eventide. If you receive a new unit *from us* in damaged condition, notify us and the carrier; we will arrange to file an insurance claim and either repair or exchange the unit.

If you receive a new unit *from a dealer* in damaged condition, notify them and the carrier.

If *we* received the unit *from you* with apparent shipping damage, we will notify you and the carrier. In this case, *you* must arrange to collect on any insurance. We will await your instructions on how to proceed with the unit, but will charge for all repairs on damaged units.

Who is covered under the warranty

The warranty applies to the *original purchaser* from an *Authorized Eventide Dealer*, providing that the dealer sold a *new* unit. *Demo* units are also covered under warranty under slightly different circumstances (see below), and units that are *used*, or have been used as part of a rental program, are *not covered* under any circumstances.

It is your responsibility to prove or to be able to prove that you have purchased the unit under circumstances that effect the warranty. A copy of your purchase invoice is normally necessary and sufficient for this.

If you have any questions about who is an *Authorized Eventide Dealer*, call us.

Units with the serial number plate defaced or removed will not be serviced.

When the warranty becomes effective

The one-year warranty period begins on the day the unit is purchased from an authorized dealer, or, if the unit is drop-shipped from Eventide, on the day shipped, plus a reasonable allowance for shipping delays. This applies *whether or not you return your warranty form*.

When we receive a unit, this is how we determine whether it is under warranty:

1. **If** the unit was shipped within the past *calendar year*, we assume that it is, unless there is evidence to the contrary, such as its having been sold used, rented, etc.
2. **If** the unit was shipped (*from our factory*) longer than a *calendar year ago*, we assume it *isn't under warranty unless*:
 - A: There is a warranty form on file showing that it has been purchased within the past year under appropriate conditions.
 - B: You send a copy of your purchase invoice indicating warranty status along with the unit.
3. **If** the unit was used as a *demo*, the warranty runs from the date that it was received by the dealer. The original purchaser gets the unexpired portion of that warranty.

When you send a unit for repair, you should indicate whether or not you believe it to be under warranty. If you do not say so, *and we charge you for the repair*, we will *not refund* unless the charge was caused by an error on our part. If you believe the unit to be under warranty and you *do say so*, but *we disagree*, you will not incur any charges until the dispute is resolved.

Reading the above, you can see that it is to your advantage to send in the warranty form when you purchase the unit. Also, if we know who you are, we can send you updates, notifications, and advise you of new products. It will also enable you to receive pre-shipment of parts discussed below.

Who performs warranty work

The *only* company authorized to perform work under this warranty is **Eventide**, Little Ferry, NJ. While you are free to give it to anyone (or to work on it yourself), we will not honor claims for payment for *labor* or *parts* from you or from third parties.

However, we and our dealers do try to be helpful in various ways:

1. Our dealers will assist, usually without charge during the warranty period in:
 - A. Determining whether there *is* a problem requiring return to the factory.
 - B. Alleviating "cockpit error" or interconnection problems that may be preventing the gear from operating to its full capability.
2. We are available for telephone consultation if the dealer is unable to assist.
3. If a part fails during the warranty period, and you wish to replace it yourself, we will normally ship the part immediately at no charge providing your warranty form is on file. (We reserve the right to request that the defective part be returned.)

Responsibility for warranty repair shipping

For us to work on your unit, it must be here. Shipping suggestions are given below. This section details who pays for it all.

Shipping within the 50 United States

You are responsible for getting it to our door at no cost to us. We cannot *accept COD* or *collect shipments*.

We will return it to you *prepaid*, at *our expense*, using an expeditious shipping method, normally United Parcel Service. In areas not served by UPS we will ship by US Mail.

If you are in a hurry, and want us to use a *premium shipping method* (such as air express, next day air, etc.) be sure you tell us so, and agree to pay shipping charges *collect*. If you specify a method that does not permit collect or COD charges, remit sufficient funds to prepay shipping.

Shipping outside the United States

If you purchased the unit from a dealer in your country, consult with them before returning the unit.

If you wish to return it to us, please note the following:

1. The unit must be *prepaid to our door*. This means that you are responsible for all shipping charges, *including customs brokerage*. When a unit is shipped to us it must be cleared through United States Customs by an authorized broker. *You must make arrangements* for this to be done. Normally, your freight forwarder has a branch in the US which can handle this transaction. We *can* arrange to clear incoming shipments for you. If you want our assistance you must *notify us before shipping goods* for repair, giving full details of the shipment, and including a minimum of \$250.00 in US funds to cover the administrative and brokerage expenses. Any balance will be applied to the repair charges, or refunded. If a balance is due to us, we will request a further prepayment.
2. *All shipments will be returned collect*. If this is impossible because of shipping regulations, or money is due us, we will request prepayment from you for the appropriate amount.
3. All funds must be in \$US. Payment may be effected by checks drawn on any bank in the US, or by telegraphic fund transfer to our bank. If you send US Currency, be sure that it is sent by a method you can trace such as registered mail. If you wish to pay by Letter of Credit, be sure that it affords sufficient time for work to be performed and the L/C negotiated, and that it is free from restrictive conditions and documentation requirements.
4. *We reserve the right to substitute freight carriers*. Although we will attempt to honor your request for a specific carrier, it is frequently necessary to select a substitute because of difficulties in communication or scheduling.

Index

Symbols

- 0-R symbol - ramp to zero/rebuilt
 - on config level $\mathcal{E}r\mathcal{E}$ mote
 - configuring RCC 24
- 0DB symbol - zero decibels
 - indicates no attenuation 14. See also input attenuation; output level
- 19-inch, rack mount 5
- 1ON symbol - config level 1online 13
- 1online 13
- 2TI symbol - config level 2time 13
- 2time 13
- 3AU symbol - config level 3audio 13
- 3audio 13
- 48000 samples per second 19
- 4PR symbol - config level 4processing 13
- 4processing 13
- 5ER symbol - config level 5error 13
- 5error 13
- 6RE symbol - config level $\mathcal{E}r\mathcal{E}$ mote 24
- 6remote 23

A

- AC
 - fuse, switch, connector 3
- adjustable values
 - configuring 13
- AES/EBU
 - configuration 19
 - operation
 - out-of-lock condition 19
 - optional audio card 19
 - unlock RCC output signal (UNL) 25
- AIO symbol - all is ok
 - in config level $\mathcal{E}r\mathcal{E}$ mote
 - set up RCC output signal 25
- All Is OK
 - RCC output signal 25
- ANA symbol - analog audio
 - on config level 3audio
 - setting fallback to analog 19
- analog outputs
 - with digital audio card 19
- artifacts
 - caused by AES/EBU sample rate change 20
- audio inputs
 - connecting to XLRs 6
 - connector detail 4
 - level control. See input level
- audio outputs
 - attenuating 6
 - connecting to 6
 - connector detail 4
 - level control. See output level

B

- bar graph
 - twin, on left. See level meters
 - under 3 digit display. See display
- basic remote control 21
- BD symbol - broadcast delay
 - during startup
 - startup delay mode selection 11
- blank display. See display digits: explanation+control of
- broadcast delay
 - configure for 34
- button
 - BYPASS. See bypass
 - CONFIGURE. See configuration
 - DUMP. See dump
 - RAMP TO ZERO. See ramp to zero
 - REBUILD. See rebuild
 - SNEEZE. See sneeze
 - WAIT AND EXIT. See wait and exit
 - WAIT FOR SAFE. See wait for safe
- BYP symbol - bypass
 - in config level 1inline
 - setting power up mode 14
 - setting the config password 14
 - in config level $\mathcal{E}r\mathcal{E}$ mote
 - set up RCC input command 24
 - set up RCC output signal 25
- bypass
 - button
 - in configuration mode 13
 - in precision fixed delay 11
 - on front panel 2
 - selecting startup operation 33
 - mode 8
 - RCC input command 24
 - RCC output signal 25
 - relay
 - set during startup 33

C

- CEN symbol - center
 - in config level 4processing
 - selecting source for processor input 15
- clear error log
 - in config mode 15
- clock rate 20
- CLR symbol - clear
 - in config level 5error
 - erase stored fatal error log 15, 16
- CNF symbol - configure
 - in config level $\mathcal{E}r\mathcal{E}$ mote
 - to configure RCC input 24
 - on entering config mode 14
- coils
 - relay
 - with basic remote control 21
- configuration
 - factory defaults
 - restoring 13, 34
 - mode 8
 - password
 - explanation+control of 16
 - use of 13
 - table of config variables 14
 - verbose description of variables 16
- configure
 - button
 - on front panel 2
 - startup command 34
 - startup description 33
 - RCC input command 24
- connectors. See rear panel
- coprocessor
 - levels set in startup 33
- coprocessor OS
 - loaded during startup 33

D

- D-R symbol - dump to rebuild
 - in config level 6remote
 - to configure RCC input 24
- decrease the delay
 - ramp to zero. *See* ramp to zero
 - wait and exit. *See* wait and exit
- delay length
 - controlling in precision fixed delay 11
 - profanity
 - explanation+control of 16, 17
 - setting in config mode 14
- diagnostics
 - built-in 33
- digital audio option 19
- DIS symbol - display digits
 - in config level 1online
 - number of display digits. *See* display digits
 - select number of display digits 14, 16
- display
 - 3-character 2
 - delay amount bar graph 2
- display digits
 - explanation+control of 16
- display error log
 - in config mode 15
- distortion
 - specification 45
- DLA symbol - delay length
 - in config level 2time
 - select profanity delay maximum length 14, 16
- DMP symbol - dump in progress
 - in config level 5-E mote
 - set up RCC output signal 25
- DS113 motherboard LED
 - operated during startup 33
- DU symbol - dump
 - in config level 1inline
 - setting the config password 14
 - in config level 2time
 - select dump amount 14–15, 16
 - in config level 5-E mote
 - to configure RCC command input 24
- dump
 - amount
 - adjustable in config mode 14
 - explanation+adjustment of 16
 - button
 - example RCC input wiring 26
 - in broadcast delay 7
 - not read thru startup 34
 - on front panel 2
 - output closure when operated 25
 - output with basic remote control 21
 - remote control with RCC 24
 - with basic remote control 21
 - indicator
 - in profanity delay 8
 - RCC input command 24
 - RCC output signal 25
 - dump into rebuild
 - explanation 25
 - RCC input command 24

E

- E-R symbol - ramp to exit/rebuild
 - in config level 5-E mote
 - to configure RCC input 24
- ERR symbol - error
 - flashing on front panel 34
 - in config level 5-E mote
 - set up RCC output signal 25
- error
 - log 34
 - processing 34
 - RCC output signal 25
 - reaction
 - adjustable in config mode 15
 - report 34
- example
 - dump control with basic remote 21
 - RCC input and output 26
- external control
 - optional RCC 25

F

- factory default
 - for individual config value 2, 13
 - restore all config values
 - startup sequence analysis 33
 - startup while holding button 34
- failure
 - response. *See* hide fatal error: defeat: key sequence
- fallback to analog audio
 - when out of lock 19
- fatal error messages
 - viewable from config mode 15
- fatal error reaction
 - adjustable in config mode 15
- fixed delay. *See* precision fixed delay
- flashing display. *See* out-of-lock condition
- FLB symbol - fall back
 - in config level 5error
 - set result of digital audio failure? 19
- frequency response
 - specification 45
- front panel
 - features described 2
 - initialized during startup 33
- FUL symbol - full delay
 - in config level 5-E mote
 - set up RCC command input 24
 - set up RCC output signal 25
- full delay
 - description 25
 - RCC output signal 25
 - remote control command 24
- fuse
 - specification 45
- fuse holder 3

G

- GLITCH
 - message on display 20

H

- HID symbol - hide
 - in config level 5error
 - selecting fatal error reaction 15
- hide fatal error 34
 - as handled during startup 33
 - defeat
 - key sequence 34

I

- increase the delay
 - rebuild. *See* rebuild
 - wait for safe. *See* wait for safe
- INL symbol - in line
 - in config level 1inline
 - setting power up mode 14
- INP symbol - input attenuation
 - does not affect AES/EBU level 20
 - in config level 3audio
 - adjust input attenuation 14
 - when first installing. *See* input attenuation
- input attenuation/level control
 - adjustable in config mode 14
 - does not affect AES/EBU levels 20
 - when first installing unit 6
- input audio. *See* audio inputs
- inputs
 - basic remote control. *See* basic remote control
 - optional remote control
 - general information 24
 - OFF (disable input) 24

J

- jumper for tests
 - startup sequence analysis 33

L

- L1 symbol - left 1
 - in config level 4processing
 - selecting source for processor input 15
- LED
 - 3 digit display. *See* display
 - bar graph. *See* bar graph
- LEF symbol - left
 - in config level 4processing
 - selecting source for processor input 15
- level meters
 - on front panel 2
 - use of 5
- LIV symbol - live (0 delay)
 - in config level 1inline
 - setting up run mode 14
 - in config level 5-*E* mote
 - set up RCC command input 24
 - set up RCC output signal 25
- live
 - RCC input command 24
 - RCC output signal 25
- lock
 - digital audio. *See* AES/EBU: operation: out-of-lock condition
 - password protect. *See* configuration: password: use of
- log of errors. *See* Error Log
- LOG symbol - log
 - error log, in config mode 16
 - in config level 5error
 - display fatal error log 15, 16
- loopback cables
 - startup sequence analysis 33

M

- maximum delay. *See* full delay
- maximum length 16
- modes of operation 8
- motherboard status LEDs
 - used during startup 33
- MUT symbol - muting audio
 - in config level 5-*E* mote
 - set up RCC command input 24
 - set up RCC output signal 25
- mute
 - controlled by RCC 25
 - RCC input command 24
 - RCC output signal 25

N

- NO SUCH FUNCTION
 - displayed during startup 33
- NO symbol
 - in config level 5error
 - clearing fatal error log 15
- NO symbol - no password
 - in config level 1inline
 - setting the config password 14
- number of digits. *See* display digits

O

- O P symbol - oscillator and pause
 - in config level 4processing
 - while adjusting oscillator selection 14
- OFF symbol - off
 - in config level 1inline
 - setting display digits 14
- OFF symbol - output off
 - in config level 5-*E* mote
 - set up RCC output signal 25
- ON symbol - on
 - in config level 5-*E* mote
 - set up RCC output signal 25
- open collector drivers
 - using optional remote card 23
- OSC symbol - oscillator. *See* oscillate
 - in config level 4processing
 - select processing mode 16
 - select rebuild method 14
- oscillate
 - explanation+control of 16
- oscillator and pause
 - adjustable in config mode 14
- OUT symbol - output attenuation
 - affects AES/EBU levels 20
 - explanation of 16
 - in config level 3audio
 - adjusts output attenuation 14
- out-of-lock. *See* AES/EBU: operation: out-of-lock condition
- output attenuation
 - adjustable in config mode 14
 - does control AES/EBU levels 20
 - explanation+control of 16
- output audio. *See* audio outputs
- outputs - rear panel
 - general information 24

P

- P symbol - Pause
 - in config level 4processing
 - while selecting oscillator mode 14
- P-- symbol - password ??
 - on entry to config mode
 - asking for password 13
- PAS symbol - password
 - in config level 1online
 - setting the config mode password 13, 14, 16
- password
 - for config mode
 - details 16
 - introduction 13
 - table of config items 14
- PAU symbol - pause
 - in config level 4processing
 - adjusting pause detection level 15, 16
- pause
 - explanation+control of 16
 - with oscillate. *See* oscillate
- pause detection level
 - adjustable in config mode 15
- pause only
 - selectable in config mode 14
- PFD. *See* precision fixed delay
- PFD symbol - precision fixed delay
 - in config level 1inline
 - setting up run mode 14
 - seen during startup 11
- pitch change
 - during AES/EBU usage 20
 - not caused by rebuild 7
- power
 - specification 45
- power switch 3
- power-up mode
 - explanation+control of 16
 - read during startup 33
 - when power is applied 5
- precision fixed delay 11
 - choosing delay mode 11
 - configure for 34
- production self test
 - in startup 33
- PUP symbol - power up
 - explanation 16
- PUP symbol - power up mode
 - in config level 1online
 - setting power up mode 14

Q

- QAL symbol - quality
 - in config level 4processing
 - adjusting quality requirement 15, 17
- quality requested
 - adjustable in config mode 15
 - explanation+control of 17

R

- R1 symbol - right 1
 - in config level 4processing
 - selecting source for processor input 15
- rack 5
- ramp to bypass
 - explanation 25
 - RCC input command 24
- ramp to zero
 - button
 - in precision fixed delay 11
 - in profanity delay 9
 - on front panel 2
 - to decrease the broadcast delay 7
 - configuring the time 14
 - external relay closure 25
 - mode 8
 - RCC input command 24
 - time
 - explanation+control of 17
- ramp to zero/rebuild
 - explanation of command 25
 - RCC input command 24
- RBM symbol - rebuild mode
 - in config level 6remote
 - set up RCC output signal 25
- RDY symbol - ready for command
 - in config level 5remote
 - set up RCC output signal 25
- REA symbol - reaction
 - in config level 5error
 - select fatal error reaction 15
 - to set error reaction 17
- reaction
 - to error condition
 - set in config mode 17
- ready
 - RCC output signal 25
- rear panel 3, 45
- REB symbol - rebuild
 - in config level 1inline
 - select run mode 14
 - setting the config password 14
 - in config level 2time
 - set rebuild time 14, 17
 - in config level 5remote
 - set up RCC command input 24
 - set up RCC output signal 25
- rebuild
 - button
 - held during startup 34
 - in precision fixed delay 11
 - in profanity delay 8
 - on front panel 2
 - to increase the broadcast delay 7
 - external relay closure 25
 - mode 8
 - RCC output signal 25
 - RCC input command 24
 - time
 - explanation+control of 17

- rebuild time
 - configuring 14
- relay bypass. *See also* bypass: button
 - triggered by BYPASS button 2
 - when fuse is blown 3
 - when power is removed 3
- relay output
 - using optional remote card 23
 - with basic remote control 21
- rELERASE*
 - displayed during startup 33
- remote control
 - basic 21
 - connector
 - on rear panel 3
 - pin description 23
 - RCC
 - configuration 24
 - connector pin description 27
- remote dump button
 - using basic remote 21
 - using RCC 26
- report
 - of error 34
- reset
 - the bd500. *See* start-up sequence
- response to a fatal error
 - controlling 34
- restoring factory defaults. *See* factory defaults: restoring
- rL symbol - right*
 - in config level 4processing
 - selecting source for processor input 15
- RS-232
 - connection
 - speed and bits 29
 - connector
 - physical description 3
 - pin description 29
 - in startup 33
- rL symbol - ramp to zero*
 - in config level 1online
 - setting the config password 14
 - in config level 2time
 - set ramp to zero time 14, 17
 - in config level 5remote
 - set up RCC command input 24
 - set up RCC output signal 25
- rL symbol - ramp to bypass*
 - in config level 5remote
 - set up RCC command input 24
- rUn symbol - run mode*
 - in config level 1online
 - where to go when exiting bypass 14, 17
- run-time mode
 - during startup 33
- RUNTIME
 - in startup 33

S

- SFF symbol - safe time*
 - in config level 1time
 - setting the profanity delay safe time 14, 17
 - in config level 5remote
 - set up RCC output signal 25
- safe delay time
 - configuring 14
 - explanation+control of 17
 - status output
 - RCC output signal 25
 - with basic remote control 21
- sample rate
 - 32000
 - feature 1
 - operate/select 19
 - 48000
 - optional feature 1
 - configuration symbol 19
 - specification 45
- Sb symbol - station break insert*
 - in config level 5remote
 - set up RCC command input 24
 - set up RCC output signal 25
- self test
 - during startup. *See* diagnostics: built-in production 34
- shipping weight
 - specification 45
- SHo symbol - show*
 - in config level 5Error
 - selecting fatal error reaction 15
- signal to noise ratio
 - basic audio
 - specification 45
- size of chassis
 - specification 45
- SnE symbol - sneeze*
 - in config level 1online
 - setting the config password 14
 - in config level 5remote
 - set up RCC command input 24
- sneeze
 - basic remote control 21
 - button 2
 - in precision fixed delay 11
 - not read through startup 34
 - stop recording temporarily 7
 - mode 8
 - RCC input command 24
- software version
 - displayed during startup 33
- source for processor input
 - adjustable in config mode 15
 - explanation+adjustment of 17
- SRC symbol - source
 - in config level 4processing
 - selecting source for processor input 15, 17
- STA symbol - static
 - in config level 5remote
 - set up RCC input command 24
- start-up sequence 33
- startup switches 34
- static 24
 - mode 8
 - RCC input command 24
- station break insert 25
 - RCC input command 24
 - RCC output signal 25

T

- tape recorder analogy 7
- ⌘E5⌘5
 - displayed during startup 33
- tests
 - self test during startup. *See* diagnostics: built-in
- THD. *See* total harmonic distortion
- time
 - dump. *See* dump: amount
 - ramp to zero. *See* ramp to zero: time
 - rebuild. *See* rebuild: time
 - safe. *See* safe time
- toggle between modes
 - using remote control 24
- total harmonic distortion
 - specification 45
- ⌘5⌘ message
 - displayed during startup 33

U

- U/L symbol - unlocked
 - in config level 5E-ror
 - selecting fallback when out of lock 19
 - in config level ⌘-E mote
 - set up RCC output signal 25
- unlock
 - no digital audio signal. *See* AES/EBU
 - RCC output signal 25
- user interface
 - in startup 33
 - operating it 5

V

- version message
 - displayed during startup 33

W

- WRE symbol - wait and exit
 - in config level *!online*
 - setting the config password 14
 - in config level ⌘-E mote
 - set up RCC command input 24
 - set up RCC signal output 25
- wait and exit
 - button
 - held during startup 34
 - in profanity delay 9
 - on front panel 2
 - to exit broadcast delay 7
 - used during startup 33
 - external relay closure 25
 - mode 8
 - RCC input command 24
- wait and exit/rebuild
 - description 25
 - remote control command 24
- wait for safe
 - button
 - in profanity delay 9
 - on front panel 2
 - to start the broadcast delay 7
 - external relay closure 25
 - mode 8
 - RCC input command 24
- weight
 - specification 45
- WFS symbol - wait for safe
 - in config level *!online*
 - setting the config password 14
 - setting up run mode 14
 - in config level ⌘-E mote
 - set up RCC command input 24
 - set up RCC output signal 25

Y

- Y55 symbol
 - in config level 5E-ror
 - clearing fatal error log 15